

# 4-ETO-100 ETHYLENE OXIDE SENSOR 0-100 PPM

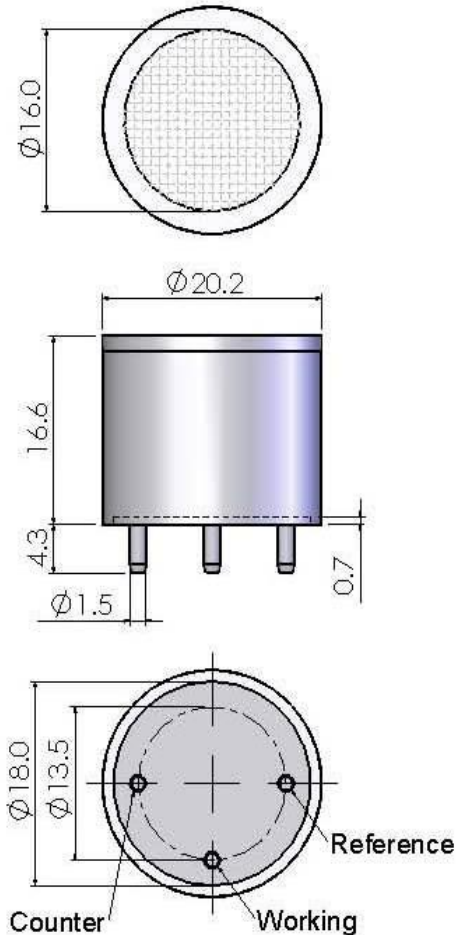

## Outline Dimensions



All dimensions are in millimetres mm.  
All tolerances are +/- 0.2mm.  
Note: PCB sockets are recommended for the sensor pin connection. Soldering to the sensor should be avoided and will invalidate warranty.  
All performance specifications are based upon the following environment conditions: +20°C, 50% relative humidity and 1 atm (1013 mBar or ambient pressure).

## SPECIFICATION – 4 SERIES

<b>Operating Principle:</b>	Electrochemical, 3-electrode cell
<b>Gas Detected:</b>	Ethylene Oxide ETO
<b>Measurement Range:</b>	0 – 100 ppm
<b>Resolution:</b>	1 ppm
<b>Expected Operating Life:</b>	2 years in air
<b>Temperature Range:</b>	-20°C to +50°C
<b>Humidity Range (non-condensing):</b>	15 – 90% RH
<b>Response Time (T90):</b>	≤ 120 seconds
<b>Long Term Sensitivity Drift:</b>	< 2% signal per month
<b>Linearity at Standard Range:</b>	Linear
<b>Sensitivity:</b>	0.25 +/- 0.125 µA/ppm
<b>Baseline (20°C):</b>	-0.2 to 2.5 µA
<b>Baseline Drift (-20°C to 40°C):</b>	0 to 10 ppm equivalent
<b>Pressure range:</b>	90 to 110 kPa
<b>Bias Potential:</b>	+ 300 mV
<b>Warranty Period:</b>	12 months from date of despatch
<b>Storage Life:</b>	6 months in sealed container
<b>Storage Temperature:</b>	0°C to +20°C
<b>Weight (approx):</b>	5 g
<b>Orientation Sensitivity:</b>	None
<b>Part Number:</b>	2112B1222400



**EURO-GAS MANAGEMENT SERVICES LTD, CHURSTON HOUSE,  
BASCOMBE ROAD, CHURSTON FERRERS, DEVON, TQ5 0JJ, UK**

**☎: +44 (0)1803 844414 Fax: +44 (0)1803 844224  
sales@euro-gasman.com www.euro-gasman.com**

**EURO-GAS**  
MANAGEMENT SERVICES LTD

# 4-ETO-100 ETHYLENE OXIDE SENSOR 0-100 PPM

## CROSS SENSITIVITY DATA

Gas	Correction Factor to ETO
Ethylene Oxide	1.0
Carbon Monoxide	2.5
Ethanol	2.0
Methanol	0.5
Isopropanol	5.0
i-Butylene	2.5
Butadiene	0.9
Ethylene	0.8
Propene	1.7
Vinyl Chloride	1.3
Vinyl Acetate	2.0
Formic Acid	3.3
Ethyl ether	2.5
Formaldehyde	1.0

**Notes:** Calibration with cross-sensitivity gas is not recommended. The cross-sensitivity may fluctuate between +/- 30% and may differ from batch to batch and within the sensor's lifetime. The cross-sensitivities are including but not limited to the above gases. The sensor may also respond to other gases.

\* Correction Factor of ETO= Sensitivity of ETO/Sensitivity of test gas.

## TEMPERATURE DEPENDENCE

Output vs Temperature

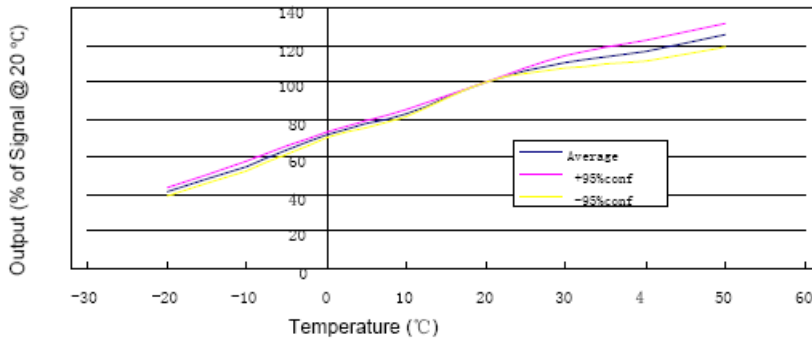

Baseline vs Temperature

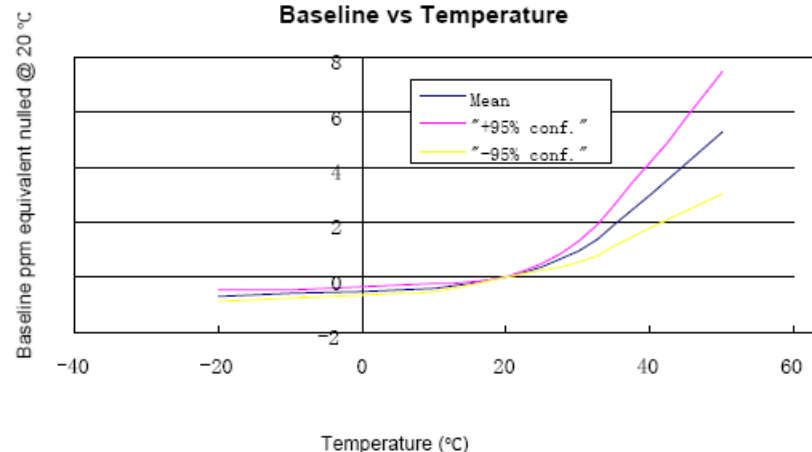

**Notes:** Sensors are designed to operate in a wide range of harsh environments and conditions. However, it is important to avoid exposure to high concentrations of solvent during storage, fitting into instrumentation and operation. When using sensors on PCBs, degreasing agents should be used prior to the sensor being fitted.

By the nature of the technology used, any sensor can potentially fail to meet specification without warning. Euro-Gas makes every effort to ensure reliability of all sensors but where life safety is a performance requirement of the product and, where practical, Euro-Gas recommends that all gas sensors and instruments using sensors are checked for response to gas before use.

The data contained in this document is believed to be accurate and reliable. The data given is for guidance only. Euro-Gas Management Services Ltd accepts no liability for any consequential losses, injury or damage resulting from the use of this datasheet or the information contained in it. Customers should test the sensors under their own conditions to ensure that the sensors are suitable for their own requirements and in accordance with the plans and circumstances of the specific project and any standards/regulations pertaining to the country in which the sensors will be utilised. Performance characteristics on this data sheet outline the performance of newly supplied sensors. Output signal can drift below the lower limit over time. This datasheet is not intended to form the basis of a contract and in the interest of product improvement, Euro-Gas reserves the right to alter design features and specifications without notice. 01/16

