

3LEL 2.3V COMBUSTIBLE GAS SENSOR

0-100% LEL

Outline Dimensions

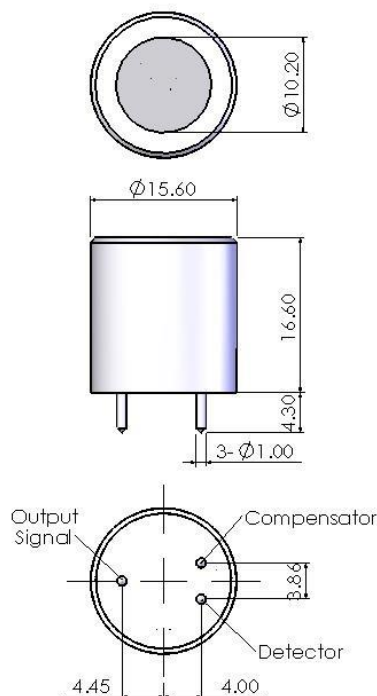

All dimensions are in millimetres mm.

All tolerances are +/- 0.2mm.

Note: PCB sockets are recommended for the sensor pin connection. Soldering or using glue with the sensor should be avoided and will invalidate warranty.

All performance specifications are based upon the following environment conditions: +20°C, 50% relative humidity and 1 atm (1013 mBar or ambient pressure).

Relative Sensitivity

Gas/Vapor	LEL (%vol)	Relative Sensitivity
Methane	5.0	100
Propane	2.1	56
n-Butane	1.9	63
n-Pentane	1.5	45
n-Hexane	1.1	31
n-Octane	1.0	26
Gasoline(unleaded)	1.3	36
Hydrogen	4.0	45
Acetone	2.5	34
Ethanol	3.3	36
m-Xylene	1.1	22
Toluene	1.1	29
Benzene	1.2	36

SPECIFICATION – MINI SERIES

Operating Principle:	Pellistor elements in certified housing
Gas Detected:	Most combustable gases and vapours
Measurement Range:	0 – 100% LEL
Temperature Range:	-20°C to +50°C
Humidity Range (non-condensing):	15 – 90% RH
Response Time (T90):	< 20 seconds (Methane CH ₄)
Long Term Sensitivity Drift:	< +/- 5% full scale signal per month
Linearity:	Linear to 0 – 75% LEL
Sensitivity:	22 +/- 8 mV / %CH ₄
Long Term Baseline Drift:	< +/- 5% LEL Methane per month
Operating Voltage:	2.3 Vdc
Operating Current:	110 +/- 10mA
Warranty Period:	12 months from date of despatch
Storage:	<u>NO</u> Si, Pb, Sn and S etc. vapours allowed
Weight (approx):	20g
Orientation Sensitivity:	None
Part Number:	2112B6112300 (CLL-6112-300)

Note: Relative sensitivities are listed for guidance only. Calibration should be carried out made using the gas under investigation for most accurate consideration. Calibration with cross-sensitivity gas is not recommended. The cross-sensitivity may fluctuate between +/- 30% and may differ from batch to batch and within the sensor's lifetime. The cross-sensitivities are including but not limited to the above gases. The sensor may also respond to other gases.



EURO-GAS MANAGEMENT SERVICES LTD, CHURSTON HOUSE,
BASCOMBE ROAD, CHURSTON FERRERS, DEVON, TQ5 0JJ, UK

☎: +44 (0)1803 844414 Fax: +44 (0)1803 844224

sales@euro-gasman.com

www.euro-gasman.com



EURO-GAS
MANAGEMENT SERVICES LTD

3LEL 2.3V COMBUSTIBLE GAS SENSOR

0-100% LEL

TEMPERATURE DEPENDENCE

Effect of Temperature on Methane Signal

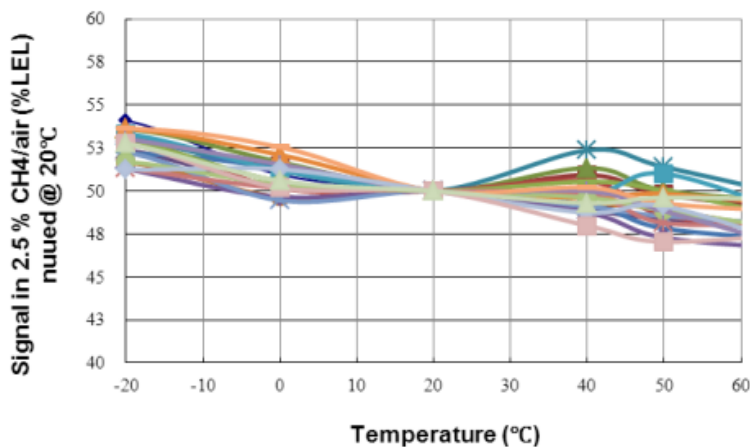

Effect of Temperature on Zero Signal

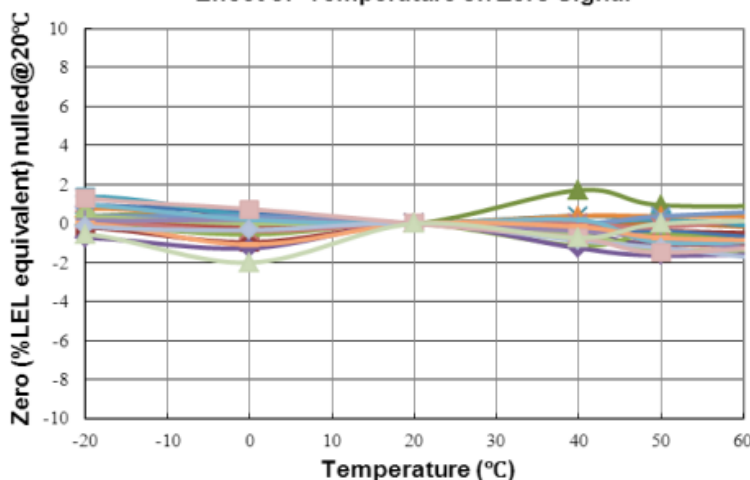

Note: Temperature dependence data is supplied for guidance only.

Notes: Sensors are designed to operate in a wide range of harsh environments and conditions. However, it is important to avoid exposure to high concentrations of solvent during storage, fitting into instrumentation and operation. When using sensors on PCBs, degreasing agents should be used prior to the sensor being fitted.

By the nature of the technology used, any sensor can potentially fail to meet specification without warning. Euro-Gas makes every effort to ensure reliability of all sensors but where life safety is a performance requirement of the product and, where practical, Euro-Gas recommends that all gas sensors and instruments using sensors are checked for response to gas before use.

The data contained in this document is believed to be accurate and reliable. The data given is for guidance only. Euro-Gas Management Services Ltd accepts no liability for any consequential losses, injury or damage resulting from the use of this datasheet or the information contained in it. Customers should test the sensors under their own conditions to ensure that the sensors are suitable for their own requirements and in accordance with the plans and circumstances of the specific project and any standards/regulations pertaining to the country in which the sensors will be utilised. Performance characteristics on this data sheet outline the performance of newly supplied sensors. Output signal can drift below the lower limit over time. This datasheet is not intended to form the basis of a contract and in the interest of product improvement, Euro-Gas reserves the right to alter design features and specifications without notice. 09/16

PRODUCT APPROVAL

- **UL**
Class I, Division I, Groups A, B, C&D Hazardous Locations
Certificate No: E187829
- **ATEX(94/9/EC)**
II 2G Ex d IIC
Certificate No: DEMKO 03 ATEX 0311958U
Certificate No: 03 ATEX 0311958U
- **IECEX**
Ex d IIC
Certificate No: IECEX UL 07.0001U

Enhanced Features

Excellent shock resistance
Excellent high concentration flush resistance
Excellent long term stability
Excellent H₂S poison resistance
Excellent HMDS poison resistance

EURO-GAS MANAGEMENT SERVICES LTD, CHURSTON HOUSE,
BASCOMBE ROAD, CHURSTON FERRERS, DEVON, TQ5 0JJ, UK

☎: +44 (0)1803 844414 Fax: +44 (0)1803 844224

sales@euro-gasman.com

www.euro-gasman.com



EURO-GAS
MANAGEMENT SERVICES LTD