

RADON SS SENSOR

1750 pCi/l



1. FEATURES

- **Easy to use advanced technology**
- **Delivers complete set of information for instantaneous and average Radon concentrations**
- **Ideal for portable, fixed and digital applications**

2. SPECIFICATION

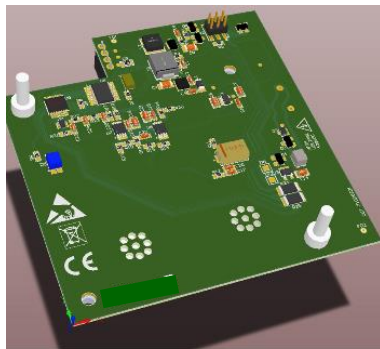

Measuring Principle:	Phototransistor sensor. Silicon with internal amplification (bipolar junction transistor) for detection of Radon daughters' alpha particles.
Detectable Gas:	Radon
Measurement Range:	0.1 – 1750 pCi/l
Sensitivity:	0.03 cpm/(pCi/l) or 1.8 cph/(pCi/l)
Field Range:	0 – 65,000 Bq/m ³
Sensitivity:	30 Bq/m ³
Data Interval:	10 minute update
Sensor Warm-Up Time:	60 minutes
Repeatability:	15 % (measured at 100pCi/l)
Resolution:	1 Bq/m ³
Accuracy:	6% (48h at 150 Bq/m ³)
Expected Operating Lifetime:	> 5 years
Warranty Period:	12 months from date of despatch
Power supply:	3.3V and Vload 4.2V
Dimensions:	80mm x 80mm x 31 mm
Part no:	2112B65000



RADON SS SENSOR

1750 pCi/l

3. OVERVIEW

ATTENTION: The OEM system must not be exposed to intense direct light! That may negatively affect the measurement.

ATTENTION: During the measurement period, the sensor temperature must be kept in the range of 0 – 40 °C.

WARNING: The OEM system internally generates High Voltage (approx. 300V). Although High voltage areas are isolated and protected, the contact area between measuring chamber and the mainboard surface can be exposed to High Voltage. Hold the OEM carefully!

4. POWER REQUIREMENTS

ATTENTION: Low quality power supply (i.e.: switching power supply) might affect the quality of the measurement. It is allowed but not recommended. Instead, it is strongly recommended that a high quality stabilised power supply is utilised for a good quality measurement.

5. PIN CONNECTIONS

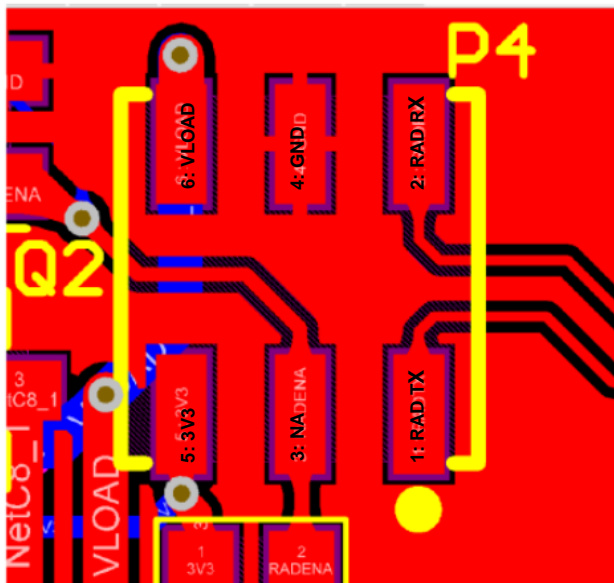

Pin 1: Tx

Pin 2: Rx

Pin 3: not to be connected

Pin 4: GND

Pin 5: 3V3 : 3.3V supply voltage

Pin 6: Vload: 4.2V supply voltage

(typical 4.4V, min 3.5V, max 5.5V)



EURO-GAS MANAGEMENT SERVICES LTD, CHURSTON HOUSE,
BASCOMBE ROAD, CHURSTON FERRERS, DEVON, TQ5 0JJ, UK

☎: +44 (0)1803 844414 Fax: +44 (0)1803 844224

sales@euro-gasman.com

www.euro-gasman.com

EURO-GAS
MANAGEMENT SERVICES LTD

RADON SS SENSOR

1750 pCi/l

6. COMMUNICATION: ELECTRIC

The two communication related pins (as indicated on the board) are: Tx and Rx.

The communication protocol is 3.3V TTL Serial Asynchronous. It follows these specifications:

Nominal voltage	3.3 V
Absolute maximum voltage	3.6 V
Speed rate	9600 bps
Data bits	8
Stop bits	1
Parity	None
Flow control	None

WARNING: Do not apply signal above 3.3 V to the communication lines (TX and Rx). This may lead to microcontroller failure and severe sensor malfunction.

7. COMMUNICATION: DIALOGUE

The sensor provides Radon concentration level every hour. Thus, the first valid data is available 1 hour after powering up.

Radon concentration data may be affected by severe variations, according to the high variability that Radon has in short-term periods. Thus, in order to obtain a more accurate representation of the data, it is recommended to use a **Mean value**.

The Mean will represent the actual Radon presence in a much better way than the instantaneous value. For a short-term analysis, it is recommended to use a 3 hour mean. For a long-term analysis, it is suggested to calculate a 12 hour mean.

The sensor sends out the instantaneous Radon level via Asynchronous communication (UART) each hour. Moreover, it is possible to communicate simple tasks to the sensor:

- Polling systems can interrogate the sensor simply by sending the 'r' character (ASCII: 114d, 72h). OEM will answer back with the last calculated value.



RADON SS SENSOR

1750 pCi/l

7. COMMUNICATION: DIALOGUE (continued)

- The sent data can have 2 different formats: 'char' and 'numeric'. For system startup, always set it to 'char'. That can be changed by sending the 'c' (ASCII: 99d, 63h) or the 'n' (ASCII: 110d, 6Eh) character respectively for 'char' and 'numeric' format. No ACK or positive feedback is sent back.
- It is possible to perform a hard reset of the system via software. That will Kill each process and will restart the system from the beginning. It is achievable by sending the 'k' (ASCII: 107d, 6Bh) character. Still, no ACK or positive feedback is sent back.

8. COMMUNICATION: FORMAT

The only data sent out by the system (when requested or every hour) is the Radon concentration level expressed in **Becquerel/m³** with a maximum of 65'000 Bq/m³. The format of the sent value is the following:

< conc >

The 'less-than sign' (ASCII: 60d, 3Ch) is followed by the concentration value, followed by the 'greater-than sign' (ASCII: 62d, 3Eh). Lastly, the Carriage Return (ASCII: CR, 13d, 0Dh) and New Line Feed (ASCII: LF, 10d, 0Ah) are sent. Concentration is expressed:

- with ASCII characters if 'char' format is activated (suitable for monitor visualization).
- with an unsigned Word value (16 bit) sent split in two unsigned Bytes (8bit). First the Most Significant Byte (MSB) is sent, then the Least Significant Byte (LSB).

ATTENTION: It may occur that the data sent out by the OEM device will show an asterisk '*' at the end of it. **The asterisk indicates a NOT-VALID data!** Some of the most common causes might be power supply problems or sensor exposed to direct light.

Examples:

Case	Data out
280 Bq/m ³ , 'char' format	< 280> (CR, LF)
280 Bq/m ³ , 'numeric' format	3Ch 01h 18h 3Eh (CR, LF)
280 Bq/m ³ , 'char' format, NOT VALID data	< 280>* (CR, LF)



RADON SS SENSOR

1750 pCi/l

9. HOW TO CONNECT INTO A SYSTEM

In order to connect the sensor via serial to another system such as a PC or microcontroller, attention is needed as to the communication port voltage level. The communication protocol is 3.3V TTL Serial Asynchronous. Communication **MUST** follow these specs:

Nominal voltage	3.3 V
Absolute maximum voltage	3.6 V
Speed rate	9600 bps
Data bits	8
Stop bits	1
Parity	None
Flow control	None

WARNING: Do not apply signal above 3.3 V to the communication lines (TX and Rx). This may lead to microcontroller failure and severe sensor malfunction.

In order to connect the sensor to a PC or microcontroller, the following scheme is recommended. Any serial enabled communication software may be utilised (Hyper Terminal – Putty or others):

Sensor to PC Connection Scheme

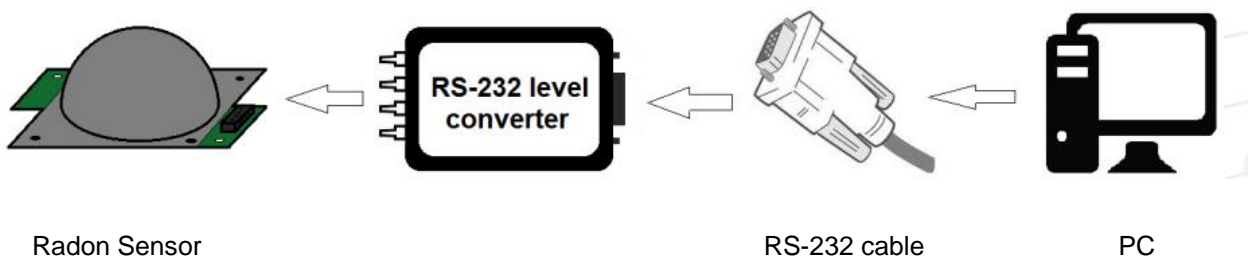

RADON SS SENSOR 1750 pCi/l

9. HOW TO CONNECT INTO A SYSTEM (continued)

In order to connect the sensor to a microcontroller or CPU that implements UART, the following scheme is recommended:

Sensor to Microcontroller Connection Scheme

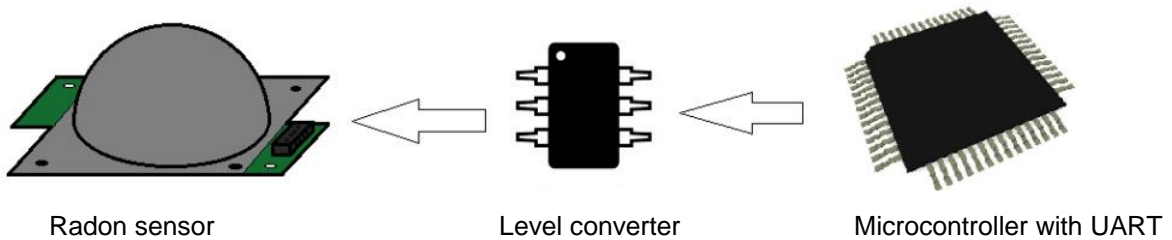

According to chapter 6, a system will be able to communicate with the sensor module by receiving concentration value (expressed as shown in chapter 7) and sending out allowed commands (as explained in chapter 6).

Example of concentration request

A PC will send the character 'r' in order to request the current Radon concentration value.

A microcontroller will be programmed to send out the word '72h' or the number 114 (decimal value) that corresponds to the ASCII character 'r'.

The system will then send back the current Radon concentration value according to the current selected format (see chapter 7).

NOTE: The sensor provides a valid Radon concentration level every hour. Thus, the first valid data that will be sent out is available 1 hour after powering up. Therefore, a 'concentration request' executed within 60 minutes from power-up will give back a zero (see chapter 7 to know how it will be shown).



RADON SS SENSOR 1750 pCi/l

10. PERFORMANCE EVALUATION

The sensor module has been exposed to different Radon concentration. The test has been performed in a 220l Radon chamber with calibrated commercial instruments as Radon reference.

- Example of Radon sensor operation.
Rn222 Concentration = [500÷1000 Bq/m³]

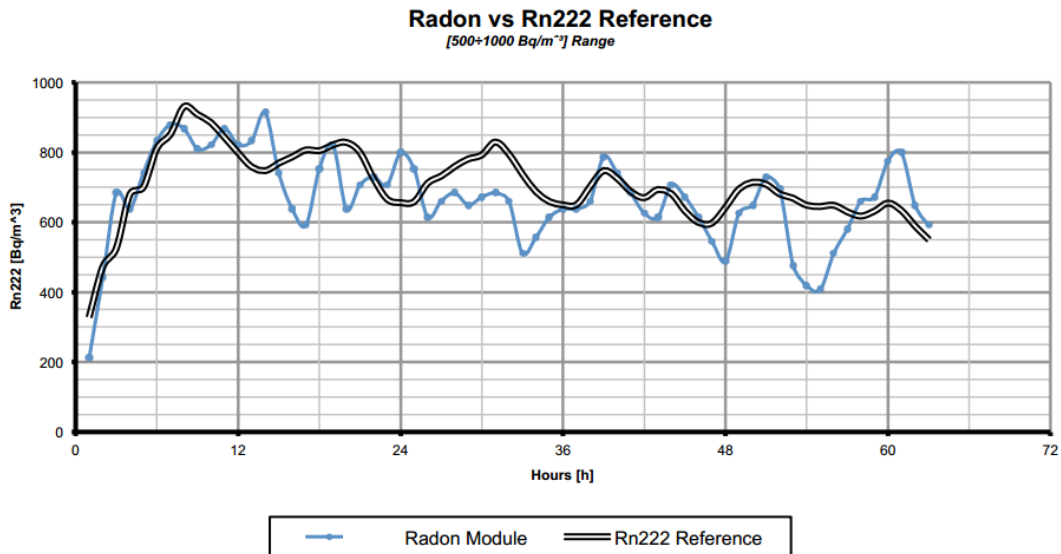

- Example of Radon sensor operation.
Rn222 Concentration = [1000÷2000 Bq/m³]

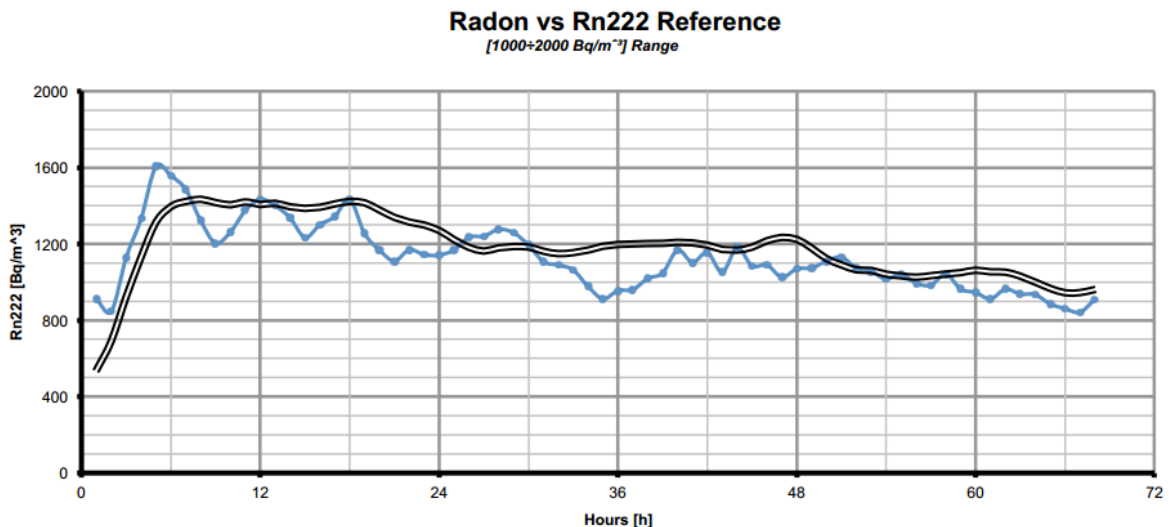

RADON SS SENSOR 1750 pCi/l

10. PERFORMANCE EVALUATION (continued)

- Example of Radon sensor operation.
 $Rn222$ Concentration = [1000÷3000 Bq/m³]

Radon vs Rn222 Reference
[1000÷3000 Bq/m³] Range

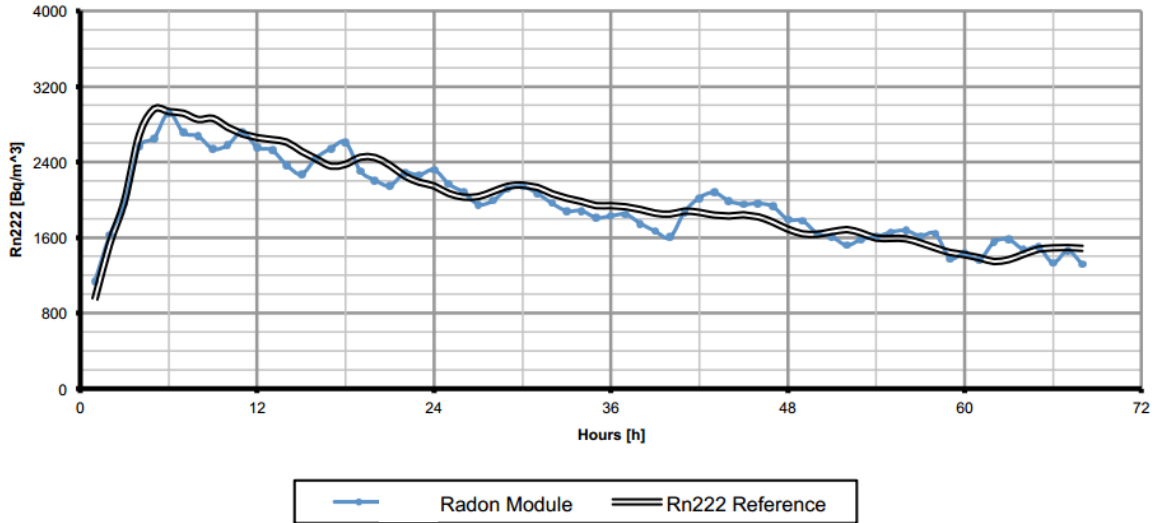

- Example of Radon sensor operation.
 $Rn222$ Concentration = [3000÷5000 Bq/m³]

Radon vs Rn222 Reference
[3000÷5000 Bq/m³] Range

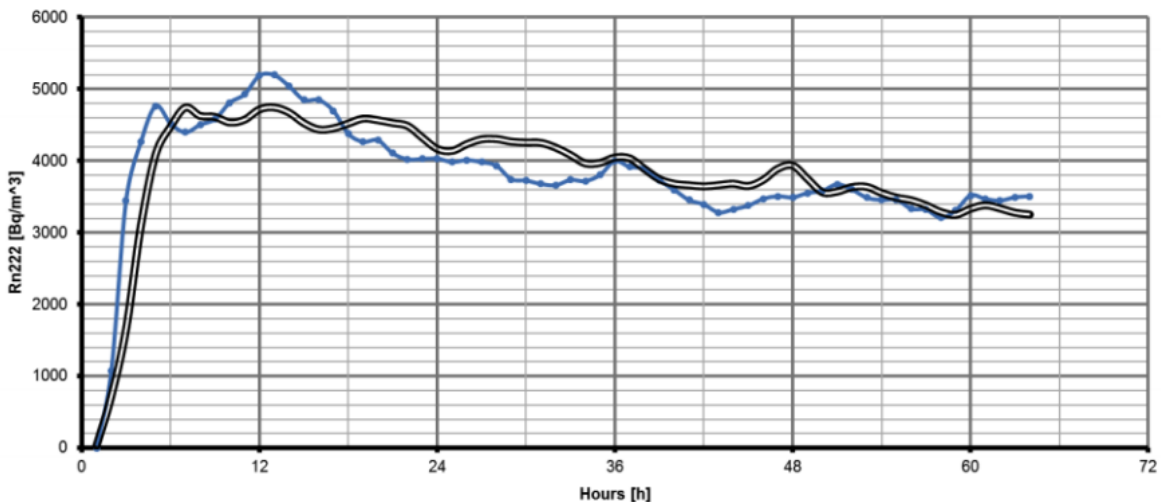

RADON SS SENSOR

1750 pCi/l

11. SPECIFICATIONS

Type	Silicon detector with internal amplification (bipolar junction transistor) for detection of Radon daughters' alpha particles.
First data out	60 minutes
Data interval	10 minute update
Sensitivity	Sensitivity 0.03 cpm/(pCi/l) or 1.8 cph/(pCi/l)
Operating temperature and humidity range	25 °C± 15 °C, RH <90%
Measuring range	0.1 – 1750 pCi/l
Reproducibility	15% (measured from last production batch calibration at 100 pCi/l)
Accuracy	±13% (min. error ± 1 pCi/l)
Power Consumption	5mA in normal operation and 1A for 100us in the charging phase of the measurement chamber, with an input Voltage on Vload pin of 4.2V
Size	8 x 8 x 4 cm



EURO-GAS MANAGEMENT SERVICES LTD, CHURSTON HOUSE,
BASCOMBE ROAD, CHURSTON FERRERS, DEVON, TQ5 0JJ, UK

☎: +44 (0)1803 844414 Fax: +44 (0)1803 844224

sales@euro-gasman.com www.euro-gasman.com

EURO-GAS
MANAGEMENT SERVICES LTD

RADON SS SENSOR 1750 pCi/l

12. DIMENSIONS

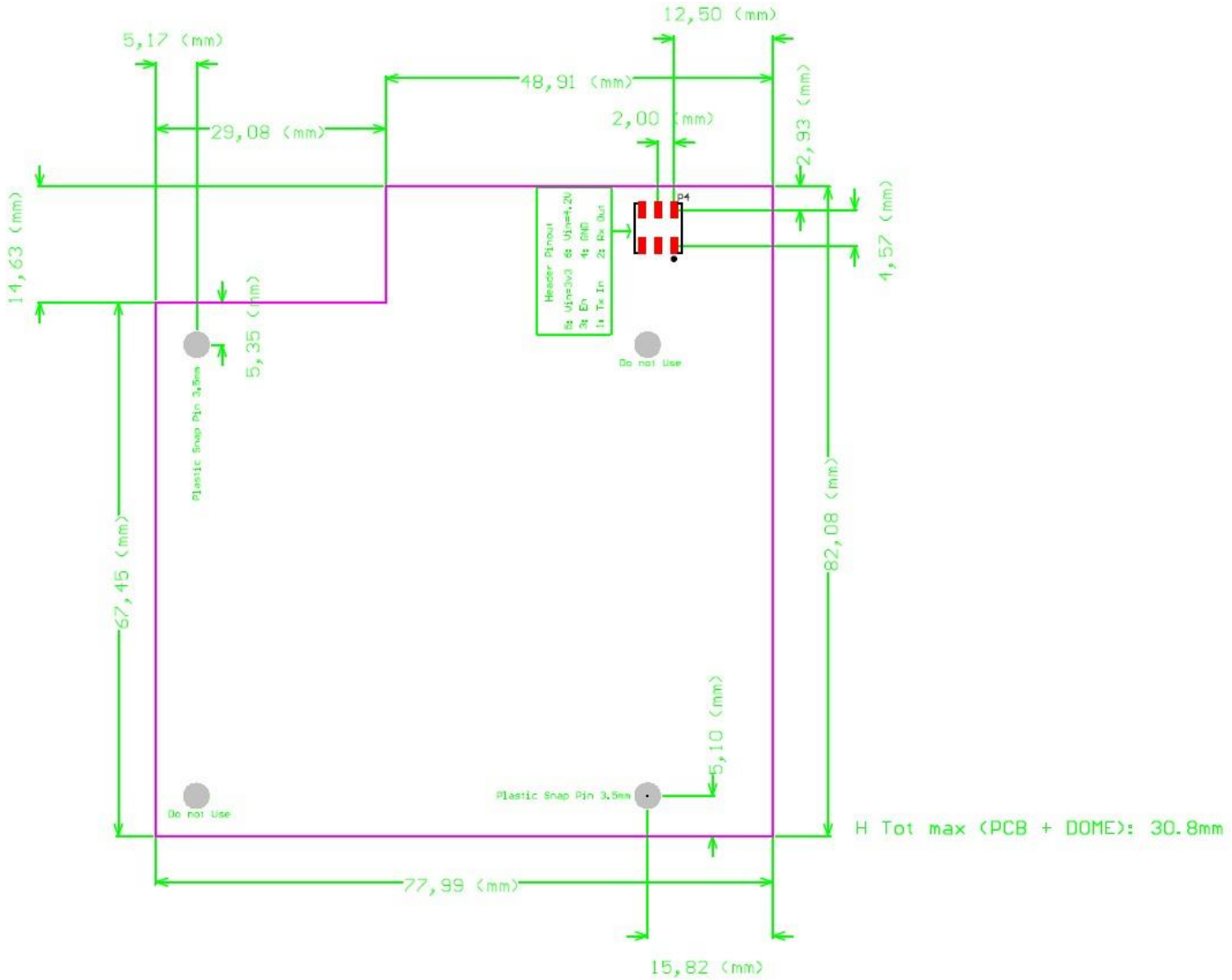

By the nature of the technology used, any sensor can potentially fail to meet specification without warning. Euro-Gas makes every effort to ensure reliability of all sensors but where life safety is a performance requirement of the product and, where practical, Euro-Gas recommends that all gas sensors and instruments using sensors are checked for response to gas before use. The data contained in this document is believed to be accurate and reliable. The data given is for guidance only. Euro-Gas Management Services Ltd accepts no liability for any consequential losses, injury or damage resulting from the use of this datasheet or the information contained in it. Customers should test the sensors under their own conditions to ensure that the sensors are suitable for their own requirements and in accordance with the plans and circumstances of the specific project and any standards/regulations pertaining to the country in which the sensors will be utilised. Performance characteristics on this data sheet outline the performance of newly supplied sensors. Output signal can drift below the lower limit over time. This datasheet is not intended to form the basis of a contract and in the interest of product improvement, Euro-Gas reserves the right to alter design features and specifications without notice. 05/17

