

MINI-CO-500 CARBON MONOXIDE SENSOR 0-500 PPM CO

Outline Dimensions

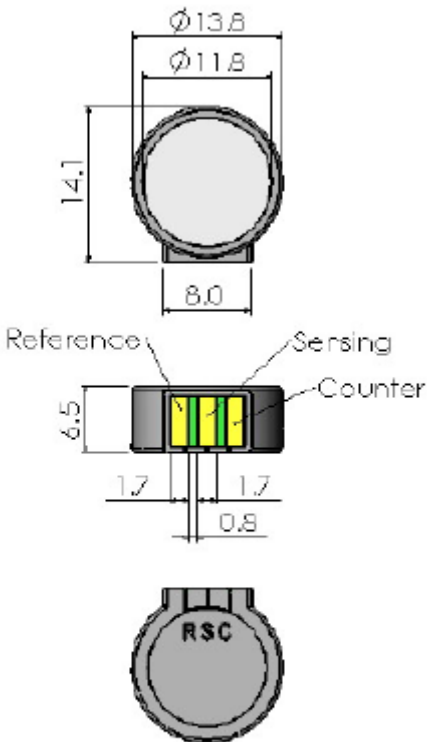

All dimensions are in millimeters.
All tolerances are ± 0.2 mm.

Note: Soldering or using glue with the sensor should be avoided and will invalidate warranty.

All performance specifications are based upon the following environment conditions: +20°C, 50% relative humidity and 1 atmospheric pressure (100 kPa or ambient pressure).

SPECIFICATION – MINI SERIES

Operating Principle:	Electrochemical, 3-electrode cell
Gas Detected:	Carbon Monoxide CO
Measurement Range:	0 – 500 ppm
Maximum Overload:	2000 ppm
Resolution:	1 ppm
Expected Operating Life:	2 years in air
Temperature Range:	-40°C to +55°C
Humidity Range (non-condensing):	15 – 90% RH
Response Time (T90):	≤ 30 seconds
Long Term Sensitivity Drift:	< 2% signal per month
Linearity at Standard Range:	Linear
Sensitivity:	0.050 +/- 0.015 μ A/ppm
Baseline (20°C):	< ± 0.2 μ A
Baseline Drift (-20°C to 40°C):	0 to 3 ppm equivalent
Pressure range:	90 to 110 kPa
Bias Potential:	0 mV
Warranty Period:	12 months from date of despatch
Storage Life:	6 months in original sealed container
Storage Temperature:	0°C to +20°C
Weight (approx):	1 g
Orientation Sensitivity:	None
Part Number:	2112B0052S00



MINI-CO-500 CARBON MONOXIDE SENSOR 0-500 PPM CO

CROSS SENSITIVITY DATA

Gas	Concentration (ppm)	Output Signal (ppm CO equivalent)
Hydrogen Sulfide	15	0.5
Sulfur Dioxide	20	0.1
Nitric Oxide	35	6
Nitrogen Dioxide	10	0.1
Hydrogen	400	70

Notes: Calibration with cross-sensitivity gas is not recommended. The cross-sensitivity may fluctuate between +/- 30% and may differ from batch to batch and within the sensor's lifetime. The cross-sensitivities are including but not limited to the above gases. The sensor may also respond to other gases.

TEMPERATURE DEPENDENCE

Fig.1 Baseline drift of Mini CO sensor

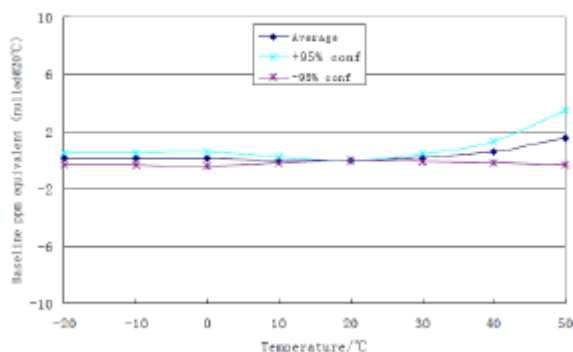
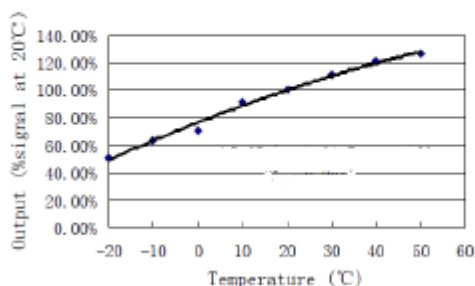

Fig.2 MINI COsensor Sensitivity Temperature Dependence



Notes: Sensors are designed to operate in a wide range of harsh environments and conditions. However, it is important to avoid exposure to high concentrations of solvent during storage, fitting into instrumentation and operation. When using sensors on PCBs, degreasing agents should be used prior to the sensor being fitted.

By the nature of the technology used, any sensor can potentially fail to meet specification without warning. Euro-Gas makes every effort to ensure reliability of all sensors but where life safety is a performance requirement of the product and, where practical, Euro-Gas recommends that all gas sensors and instruments using sensors are checked for response to gas before use.

The data contained in this document is believed to be accurate and reliable. The data given is for guidance only. Euro-Gas Management Services Ltd accepts no liability for any consequential losses, injury or damage resulting from the use of this datasheet or the information contained in it. Customers should test the sensors under their own conditions to ensure that the sensors are suitable for their own requirements and in accordance with the plans and circumstances of the specific project and any standards/regulations pertaining to the country in which the sensors will be utilised. Performance characteristics on this data sheet outline the performance of newly supplied sensors. Output signal can drift below the lower limit over time. This datasheet is not intended to form the basis of a contract and in the interest of product improvement, Euro-Gas reserves the right to alter design features and specifications without notice. 08/16

