

MOX2 GAS SENSOR

002772

Issue 10

MediceL[®] Oxygen (O₂) Gas Sensor



Oxygen (O₂) Gas Sensor:

MOX2

Part Number: AA829-220

DESCRIPTION

MediceL[®] (MOX) Sensors include oxygen and a range of other gases that are designed specifically for use in respiratory and anesthesia applications.

DOCUMENT PURPOSE

The purpose of this document is to present the performance specification of the MOX2 oxygen gas sensor.

This document should be used in conjunction with the Operating Principles (OP04) and the Product Safety Datasheet (PSDS 4).

The data provided in this document are valid at 20°C, 50 %RH and 1013 mBar for three months from the date of sensor manufacture.

Output signal can drift below the lower limit over time. For guidance on the safe use of the sensor, please refer to the instructions for use.

APPLICATIONS

- Critical care anesthesia

PORTFOLIO

The MOX MediceL[®] sensor family is part of the extensive line of Honeywell gas sensors. To learn more about the product, or other gas sensors in this series, please contact us.

FEATURES AND BENEFITS



Meets the accuracy requirements of ISO 80601-2-55



Linear output from 0 % to 100 % oxygen



13 month warranty



RoHS compliant

MEDICEL® GAS SENSORS

MOX2 SERIES

TABLE 1. TECHNICAL SPECIFICATIONS

MEASUREMENT	
Operating Principle	Partial Pressure Electrochemical
Output	9 mV to 13 mV in 210 mBar O ₂
Measurement Range	0 mBar to 1500 mBar O ₂
T90 Response Time	< 15 s (air to 100 % O ₂)
Baseline Offset	< 200 μV
Linearity	Linear 0 % to 100 % O ₂ (See Note 1)
ELECTRICAL	
Temperature Compensation	< 2 % O ₂ equivalent (0°C to 40°C)
External Load Resistor	10 kOhm minimum (See Important Note)
Connector	3,5 mm [0.141 in] mini phone jack
Recommended Mating Part	Lead part number: B047
MECHANICAL	
Weight	42 g (nominal)
Housing Material	White ABS
Orientation	Any
ENVIRONMENTAL	
Operating Temperature Range	-20°C to 50°C
Operating Pressure Range	0.5 Bar to 2.0 Bar
Operating Humidity Range	0 %RH to 99 %RH non-condensing
LIFETIME	
Long Term Output Drift in 100 % O₂	< 5 % signal loss/year
Recommended Storage Temperature	-10°C to 40°C (Short excursions to 50°C allowed)
Expected Operating Life	1.5 x 10 ⁶ % O ₂ hours at 20°C 0.8 x 10 ⁶ % O ₂ hours at 40°C
Packaging	Sealed blister
Standard Warranty	13 months from date of m (This amounts to a variation of condition 1 of our standard terms and conditions which otherwise apply)

Note 1: Use of a regression coefficient shows a best fit straight line better than 0.9995 when measured through the four data points from testing with 100 % N₂, 21 % O₂, 60 % O₂ and 100 % O₂

*Specifications are valid at 20°C, 50 %RH, and 1013 mBar using recommended circuitry. Performance characteristics outline the performance of sensors supplied within the first three months. Output signal can drift below the lower limit over time.

All performance data is based on measurements made with cylinder gases using a flow rate of 100 mls/min. Conditions at 20°C, 50 % RH and 1013 mBar.

Product Dimensions

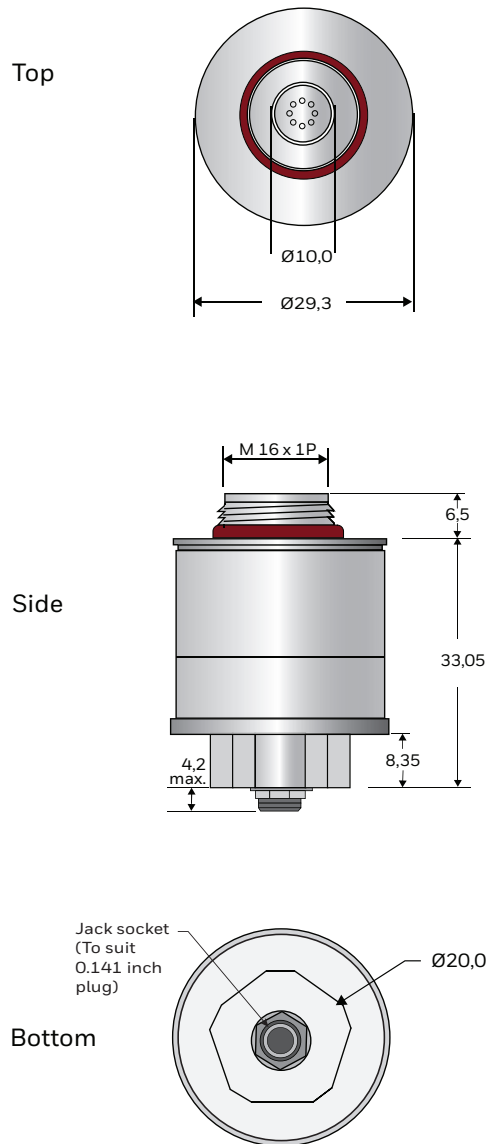

All dimensions in mm

All tolerances $\pm 0,15$ mm unless otherwise stated

IMPORTANT NOTES

Connection should be made via mating parts only. Soldering to the sensor will result in damage and invalidate the warranty.

For further information on the external load resistance and connection to the recommended mating part, please see Operating Principle OPO4.

MEDICEL® GAS SENSORS

MOX2 SERIES

Poisoning

MediceLs are designed for operation in a wide range of environments and harsh conditions. However, it is important that exposure to high concentrations of solvent vapours is avoided, both during storage, fitting into instruments and operation. When using sensors with printed circuit boards (PCBs), degreasing agents should be used before the sensor is fitted. Do not glue directly on or near the MediceL as the solvent may cause crazing of the plastic.

Intended Use

These sensors are designed to be used to monitor the partial pressure of oxygen in anaesthesia (not including xenon), critical care, neonatal incubators and general oxygen monitors.

Stabilisation Time

Allow at least 15 minutes to stabilise in the instrument before calibration or refer to manufacturers instructions.

Cleaning and Sterilisation

In case of contamination the sensor may be cleaned with distilled water and allowed to dry naturally. The sensor is not suitable for sterilisation by steam or exposure to chemicals such as ethylene oxide or hydrogen peroxide.

Calibration Interval

These sensors are designed to have minimal drift over their useful lifetime. For maximum accuracy, however they should be calibrated before each use.

If the Sensor is Dropped

If a sensor is dropped, then it should be placed in quarantine for 24 hours and a follow-up check made by a 2-point calibration.

Mechanical Installation

When installing the sensor, it must only be screwed in hand-tight and a gas-tight seal ensured. Spanners and similar mechanical aids may not be used, as excessive force may damage the sensor thread.

RFI/EMI Susceptibility

MediceLs contain metal and may be susceptible to RFI or EMI. They are not suitable for use in MRI environments.

Certifications



0123

This product has been licensed for sale by the FDA in the US. For confirmation, see: <http://www.accessdata.fda.gov/scripts/cdrh/cfdocs/cfr/rl.cfm?lid=604764&lpcd=CCL>

MEDICEL® GAS SENSORS

MOX2 SERIES

Cross Sensitivity Table

The table below shows how MOX2 MediceLs respond when tested with the gas mixtures listed in ISO 80601-2-55.

TABLE 2. CROSS SENSITIVITY	
TEST GAS	% O ₂ ERROR
50 % HE / 50 % O ₂	< 1 %
60 % N ₂ O / 40 % O ₂	< 1 %
2 % Halothane / 40 % O ₂ / 30 % N ₂ O / 5 % CO ₂ / Bal N ₂	< 1.5 %
2 % Enflurane / 40 % O ₂ / 30 % N ₂ O / 5 % CO ₂ / Bal N ₂	< 1.5 %
2 % Isoflurane / 40 % O ₂ / 30 % N ₂ O / 5 % CO ₂ / Bal N ₂	< 1.5 %

MOX Adaptor (15 mm Taper)

MOX2 sensors are supplied with an adaptor that can be fitted to the sensor thread and used to direct as flow to the sensor.

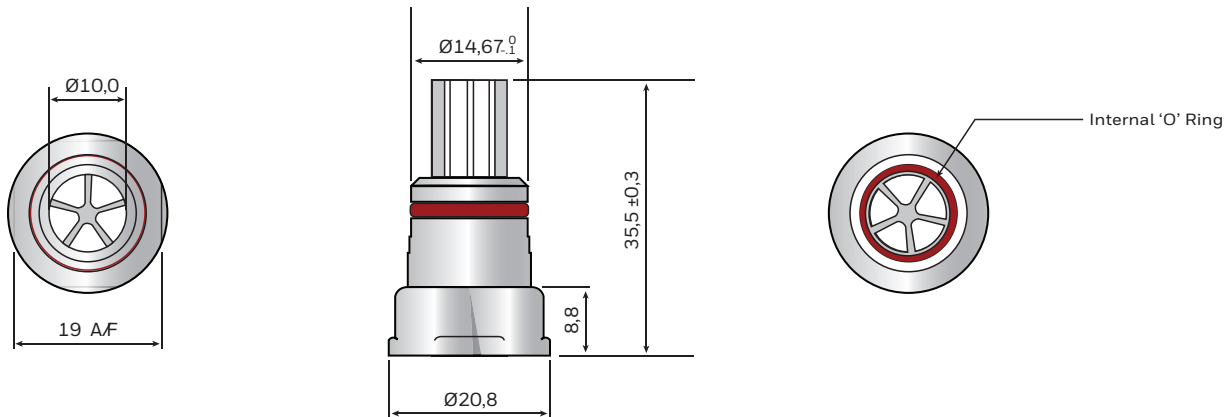

All dimensions in mm

WARRANTY/REMEDY

The manufacturer warrants goods of its manufacture as being free of defective materials and faulty workmanship during the applicable warranty period. The manufacturer's standard product warranty applies unless agreed in writing; please refer to your order acknowledgment or consult your local sales office for specific warranty details. If warranted goods are returned to during the period of coverage, the Manufacturer will repair or replace, at its option, without charge those items that the manufacturer, in its sole discretion, finds defective. **The foregoing is buyer's sole remedy and is in lieu of all other warranties, expressed or implied, including those of merchantability and fitness for a particular purpose. In no event shall the manufacturer be liable for consequential, special, or indirect damages.**

While we may provide application assistance personally, through our literature and the web site, it is buyer's sole responsibility to determine the suitability of the product in the application.

Specifications may change without notice. The information we supply is believed to be accurate and reliable as of this writing. However, we assume no responsibility for its use.

MediceL® is a trademark or registered trademark of Honeywell International, Inc., in the United States and other countries.

ECN-50488
002772-10-EN | 10 | 02/25
© 2025 Honeywell International Inc. All rights reserved.

• WARNING MISUSE OF DOCUMENTATION

- The information presented in this product sheet is for reference only. Do not use this document as a product installation guide.
- Complete installation, operation, and maintenance information is provided in the instructions for use.

Failure to comply with these instructions could result in death or serious injury.

SAFETY NOTE

This sensor is designed to be used in safety critical applications. To ensure that the sensor and/or instrument in which it is used, are operating properly, it is a requirement that the function of the device is confirmed by exposure to target gas (bump check) before each use of the sensor and/or instrument. Failure to carry out such tests may jeopardize the safety of people and property.