

Ammonia Gas Sensor Modules

NH3-10 / NH3-50 / NH3-100
SS Micro TX

0-10ppm NH3, 0-50ppm NH3, 0-100ppm NH3

Technical Specifications

» Overview

The SS Micro TX series are intelligent digital gas sensor modules using smart microprocessor, combining high-reliability solid polymer electrochemical gas sensor technology and intelligent algorithm calculation. The modules are suitable for both indoor and outdoor industrial applications. Each module detects gas, temperature and humidity and receives all data simultaneously. The data is output through the transmission command, which makes it easy and convenient to recognise the right time for maintenance and replacement. Each sensor module has been professionally calibrated with the gas, and the calibration information is stored in the flash chip. The sensor module has an I²C or a UART (TTL 3.3 V) output interface, which can be easily integrated with different devices and systems.

» Key Features

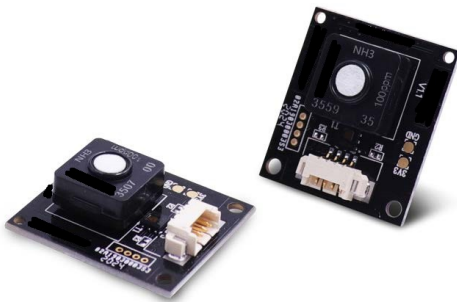

- ☞ Excellent accuracy
- ☞ Detects gas, temperature and humidity
- ☞ Detects with high selectivity a wide variety of gases
- ☞ Digital signal UART (TTL 3.3 V) or I²C output
- ☞ Low power consumption and sleep mode (suitable for battery and IoT applications)
- ☞ Long lifetime > 5 years
- ☞ No poisoning
- ☞ Typical warm-up time in seconds
- ☞ Fast response time
- ☞ Linear output
- ☞ No zero line drift
- ☞ Wide temperature range of -20 °C to +55 °C
- ☞ No leakage
- ☞ RoHS approved

» Applications



- | | |
|--------------------------------|--------------------------|
| ☞ Industrial Safety | ☞ Biogas |
| ☞ Leakage Detection | ☞ Garbage Disposal |
| ☞ Emission Monitoring | ☞ Semiconductor Industry |
| ☞ Sewage/Water Treatment Plant | ☞ Livestock Farming |



» Principle

The SS Micro TX series uses solid polymer electrochemical technology; a revolutionary innovation in the field of electrochemical detection. This technology is based on the principle of electrochemical catalytic reaction, detecting the output signals of the electrochemical reactions of different gases and accurately measuring the gas concentration through the signal. The sensor is composed of three electrodes in contact with the electrolyte. A typical electrode consists of a large surface area of noble metal and other materials. The electrode, electrolyte and the surrounding air are in contact and the gas diffuses into the working electrode. Here the gas will be oxidized, causing a current which is proportional to the gas concentration.

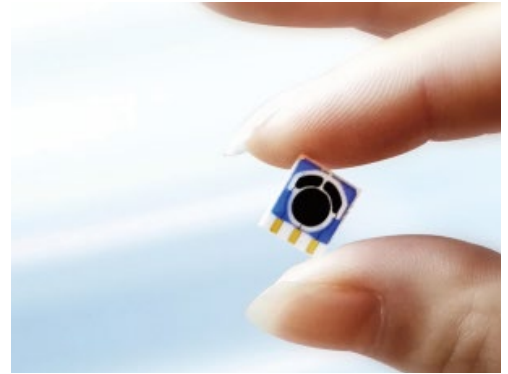

» Mechanical Drawing (Unit: mm)

Dimensions diagram

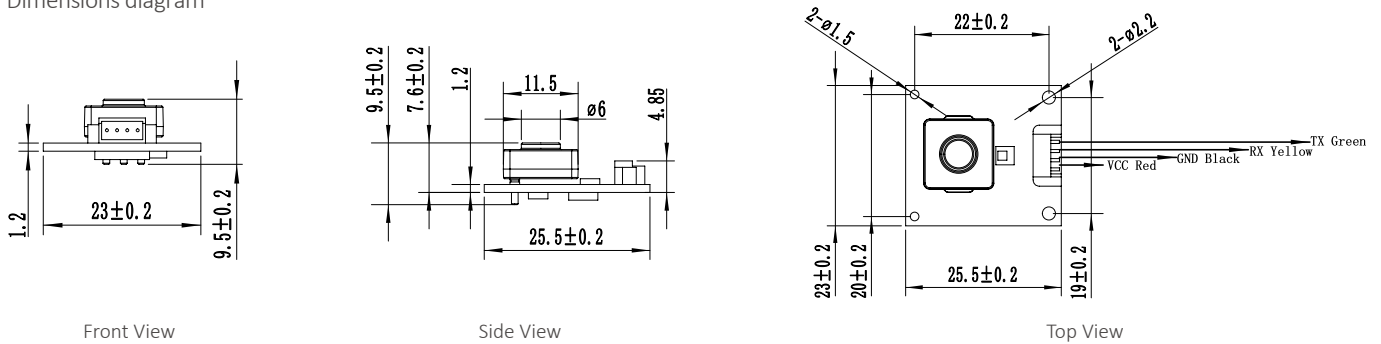

4 pin Cable Diagram

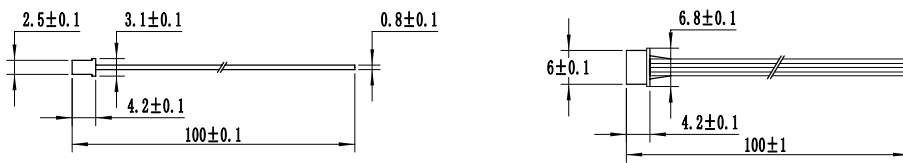

Interface definition:

- TX- green
- RX- yellow
- GND- black
- VCC- red

» Order Information

Product	Part number	Range	Resolution	Output
NH3-10 Micro TX UART or i2C output	2112B012770510	0-10ppm	0.001ppm	UART TTL 3.3V or I2C
NH3-50 Micro TX UART or i2C output	2112B012770550	0-50ppm	0.01ppm	UART TTL 3.3V or I2C
NH3-100 Micro TX UART or i2C output	2112B0127705100	0-100ppm	0.01ppm	UART TTL 3.3V or I2C
4-pin Cable	2112B012762			
UART USB Connector with 4-pin Cable	2112B012763			
Test and calibration gas flow cap	2112B013701			

Technology Specifications

Gas Sensor Specifications

Principle	Solid Polymer Electrochemical Sensing Technology
Detection Gas	Ammonia Gas
Accuracy	± 5% (Measurement value)
Repeatability	1 %
Linearity	Linear
Long-Term Drift	< 5 %/year
Expected Lifetime	> 5 years

Temperature & Relative Humidity Sensor Specification

Temperature Range	-20 °C to +70 °C
Temperature Accuracy	± 0.2 °C (Typical Value)
Humidity Range	0 to 100% RH
Humidity Accuracy	± 2 % (Typical Value)

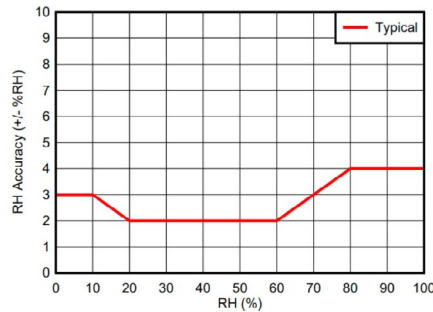
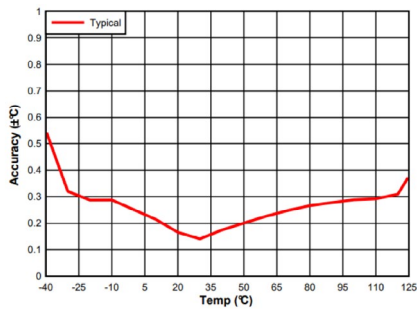

Environment Specifications

Working Temperature	-20 °C to +55 °C
Working Humidity	15-95% RH. (Non-condensing)
Working Pressure	Atmospheric pressure ± 10 %

Mechanical Specifications

Size (Including gas sensor)	23 x 25.5 x 9.5 mm
Size (Without gas sensor)	23 x 25.5 x 4.85 mm
Weight	3.1 g
Warranty	12 months from the date of manufacture
Cable Length	100 mm, special length by request

Technology Specifications

Electrical Specifications

Output Signal	UART (TTL 3.3 V) or I ² C digital signal, for more information please see "Communication Protocol"
	UART Interface definition: VCC- red, GND- black, RX- yellow, TX- green
	UART Baud rate: 9600 Data bits: 8 bits Stop bits: 1 bit
	I ² C Interface definition: VCC-red, GND-black, SDA-yellow, SCL-green
	I ² C Frequency: ≤ 20 kHz I ² C Signal Voltage: 3.3 V

UART TTL 3.3V

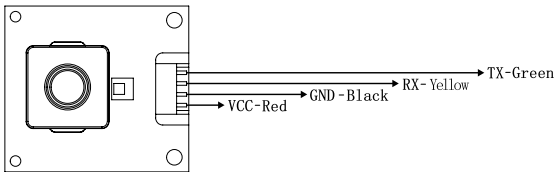

I²C 3.3V

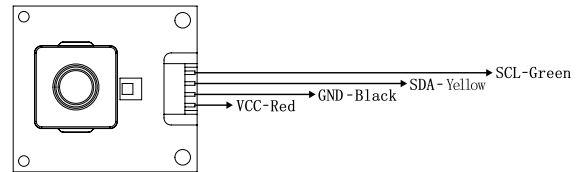

Communication Notes	1) Communication has active upload and Q&A mode. The default mode is Q&A mode after power-on. You can use instructions to switch between the two modes.	
	2) If you switch off the module or switch to sleep mode, the module remains in Q&A mode.	
Supply Voltage	3.3 to 5.5V DC, Recommended 5V DC	
Working Current	< 5 mA	
Peak Current	UART: 4.2 mA @ 5V DC	I ² C: 6.2 mA @ 5V DC
Current (Switch on LED lamp)	UART: 2.9 mA @ 5V DC	I ² C: 4.7 mA @ 5V DC
Current (Switch off LED lamp)	UART: 1.6 mA @ 5V DC	I ² C: 3.4 mA @ 5V DC
Sleep Mode Current	UART: 0.8 mA @ 5V DC	I ² C: 0.9 mA @ 5V DC
Power Consumption	UART: 12.5 mW @ 5V DC	I ² C: 23.5 mW @ 5V DC
Sleep Mode Power Consumption	UART: 4 mW @ 5V DC	I ² C: 4.5 mW @ 5V DC

Certifications

RoHS Certification

User Guide

Thank you for choosing SS Micro TX Gas module. Before using it, please read this document in detail in order to use our products correctly and effectively.

Storage

The solid polymer sensor can be stored for more than 1 year at a humidity of 20-95% and a temperature of -5 to +25°C . Ensure that the storage environment is free from high concentrations of contaminated gases. Sensors that have been stored for 6 months should first have a power-on polarization time of more than 12 hours to fully activate the electrolyte and restore best detection state.

1. The best storage environment is: temperature -5°C to +25°C , relative humidity 25% - 95% (non-condensing);
2. The storage environment should be clean air, no pollution gas, no high concentration organic gas, no dust, no smoke;
3. Avoid storage with alcohol (ethanol), perfume, sodium silicate, and polyurethane liquids and solids.

Packaging and transportation

1. Avoid prolonged direct sunlight during transportation, prevent rainwater penetration;
2. Transport packaging should provide protection with shock-proof bubble film or odourless environmentally friendly sponge;
3. During long-term long-distance transportation, the temperature in the sensor package should be kept below 40°C as much as possible, and the maximum temperature should not exceed 55°C (do not store or use at this temperature for a long time);
4. During the transportation of the finished product, seal the air inlet of the sensor as much as possible to prevent contaminated gas from entering the sensor, which will cause high values or long stabilization time when the product is used for the first time.

Steps for usage

1. Wiring

- Perform the corresponding wiring according to the identification of the output signal port of the structure diagram. Please refer to the 4 Pin signal line label in the "Structure Diagram" above. For the power supply, see the voltage and current ranges marked in the indicators. **Note: incorrect wiring will cause the module to malfunction or damage the module.**

2. Warm-up time

- The module needs a short stabilisation time after power-on. The module is designed with plug-and-play function, and usually the stabilisation time is within 2 minutes. However, if the concentration of contaminated gas is high during storage, transportation or on-site environment, the stabilisation time will increase. If the on-site ambient air is highly fluid, there will be fluctuations in the data. Please pay close attention to the on-site environment status. When the environmental condition is stable and there is no strong convection and air exchange (such as open windows, open doors, fans, air conditioners, fresh air systems, etc.), as soon as the output signal is constant, detection can begin .
- (Note: Since it is a ppb-level high-precision module, the first power-on stabilisation time varies under different storage and measurement environments.)

3. Diffusion use

- The module functions by diffusion detection with ambient gas, that is, the airflow naturally diffuses into the sensor. When the environment has a flow rate, it is necessary to ensure that the flow rate is within 500ml and that the flow rate is stable. The change of flow will cause the signal to fluctuate. When the flow is large, it will bring a change of pressure, which will cause the sensor signal value to change. The flow velocity will generate pressure, and the change in pressure will cause the output signal to change. The signal will increase when the pressure increases and the sensor signal will change suddenly when the pressure changes suddenly. Avoid negative pressure environments, which will cause irreparable physical damage to the sensor.

4. Temperature and humidity effects

- The detection module has been corrected for temperature compensation through an intelligent algorithm.

User Guide

- The sensor is not affected by normal humidity changes, but rapid humidity changes will cause instantaneous peak changes. This is mainly due to condensation on the sensor surface caused by humidity changes, which will prevent outside air from entering the sensor, but the sensor will stabilize in a short time. Frequent and rapid changes in temperature or humidity will affect the chemical materials and cause the sensor life to be unexpectedly reduced. Due to the principle and characteristics of electrochemical sensors, changes in the environment have different levels of influence on the chemical electrolyte inside the sensor. The SS Micro TX module analyzes the changes of the sensor's current data in detail through different environmental temperature and humidity impact tests, and combines the temperature and humidity sensor data to perform algorithmic compensation. During use of the sensor, pay attention to sudden changes in temperature and humidity which will cause the sensor data to fluctuate abnormally. The sensor has good adaptability to the environment. Generally, it can fully adapt to the new environment and stabilize in 5-10 minutes.
- The sensor module must not be used and stored for a long time in a high-temperature and low-humidity environment with humidity below 10% and a temperature above 55°C. Doing so may result in reduced sensor life, or failure, or invalid test data.

Precautions

1. The main function of the gas sensor is to detect the gas composition and content. Please do not let any part of the sensor contact liquid;
2. Different gas sensors have different measurement concentration ranges. Do not measure high-concentration gases for a long time period;
3. The white or yellow sheet on the sensor is a waterproof and breathable film - please be careful not to scratch or pull it off;
4. Do not block or contaminate the surface of the sensor. Sometimes blockage of the hole is the cause of reduced sensitivity and slow response time;
5. Please do not exchange the sensors of different gas modules. Doing so will cause measurement errors, because all the parameters of each sensor and each circuit board are matched and calibrated, and there will be deviations after the exchange;
6. Once the micro sensor is unplugged and re-inserted into the circuit board, please check that the three electrodes of the sensor correspond to the socket on the circuit board correctly to avoid irreversible damage to the sensor after reverse insertion;
7. Avoid excessive impact or vibration. Please ensure that the structure is not damaged before use. If the case is damaged, please ensure that the structure is undamaged. If the case is broken and the internal structure is exposed, the output will no longer be reliable;
8. Pins must not be broken or bent. Doing so may damage the internal structure of the sensor;
9. The sensor will be slow to return to the initial state after long-term use in a high-concentration gas environment. The recovery speed is proportional to the overrange multiple;
10. The low range sensors should not be used in high concentrations and strong viscous gas for a long time period;
11. Please do not disassemble the sensor as it will damage the sensor;
12. Measurement range and accuracy. Select a gas sensor that matches the range and accuracy according to the actual application requirements and the gas concentration range. Otherwise, the gas may not be detected, accurate data may not be judged, and the sensor may be damaged;
13. When conducting on-site detection of target gas, avoid the interference of other high-concentration gases on the site, which will cause the error rate of the test results to increase.
14. Due to the principle and characteristics of the electrochemical sensor, in order to ensure long life and best working state of the sensor, the sensor should be kept in a continuous power state as much as possible;
15. When the module encounters high-concentration gases during use, such as target gas, ethanol gas, and volatile organic gas, after impact the recovery time is slower. Placement in a clean air environment can shorten the recovery time.

Sensor quality inspection

1. Each sensor produced is factory inspected, with a comprehensive performance test of the main indicators of the sensor. In the sensor manufacturing process, we perform four index tests in different process links to screen out nonconforming products. After production and before delivery, each sensor is tested. The sensors are installed in a gas distribution test system, and tested with full-scale certified standard gas for a continuous 3-5 minutes. After the test is completed, the system generates resulting test reports (including: serial number, sensitivity, response time T50 T90, zero return time, zero current, maximum current value) strictly in accordance with the system preset parameters of standard qualified product. Sensors are rejected where standards are not met and then treated as nonconforming products.

User Guide

2. All modules are calibrated with certified standard gas for calibration to ensure the consistency and accuracy of the sensor.

Disclaimer

Performance data stated above is based on data obtained with new sensors under test conditions of 26°C, 55% RH, Flow rate 3000sccm, air space: 0.03m3, standard atmospheric pressure environment, using our gas distribution system and test software.

Cross sensitivity gases are not target gases. Performance characteristics on this data sheet outline the performance of newly supplied sensors. Output signal can drift below the lower limit over time. Relationships and performance can change with ageing of the sensor.

Sensors are designed to operate in a wide range of harsh environments and conditions. However, it is important to avoid exposure to high concentrations of solvent during storage, fitting into instrumentation and operation. By the nature of the technology used, any sensor can potentially fail to meet specification without warning. Euro-Gas makes every effort to ensure reliability of all sensors but where life safety is a performance requirement of the product and, where practical, Euro-Gas recommends that all gas sensors and instruments using sensors are checked for response to gas before use.

At the end of the product's service life, please do not discard any electronics in household waste. Please dispose it in accordance with local government regulations on electronic waste recycling.

The data contained in this document is believed to be accurate and reliable. The data given is for guidance only. Euro-Gas Management Services Ltd accepts no liability for any consequential losses, injury or damage resulting from the use of this datasheet or the information contained in it. Customers should test the sensors under their own conditions to ensure that the sensors are suitable for their own requirements and in accordance with the plans and circumstances of the specific project and any standards/regulations pertaining to the country in which the sensors will be utilised.

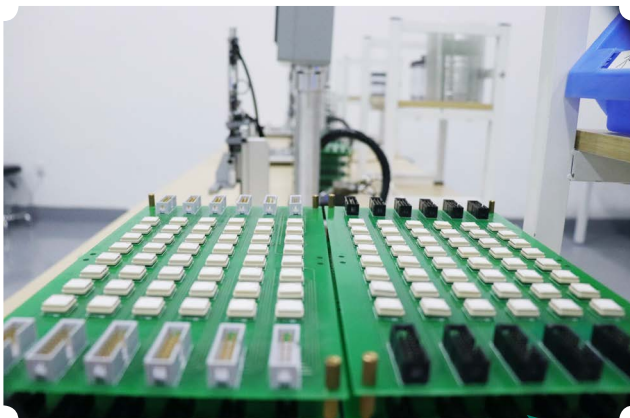

Sensor Production Test

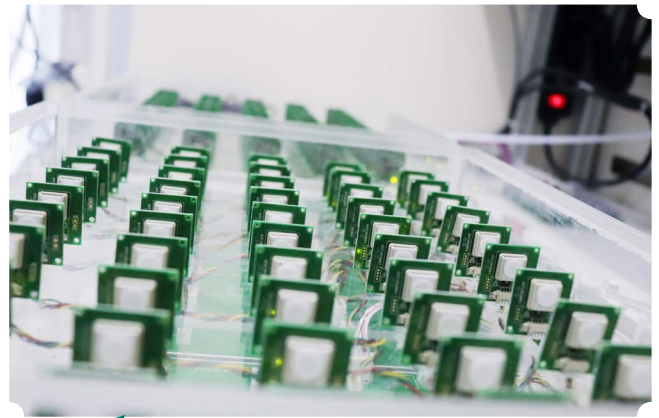

Test module, test calibration

This datasheet is not intended to form the basis of a contract and in the interest of continued product improvement, Euro-Gas reserves the right to change design features and specifications without prior notification. We do not accept any legal responsibility for customer applications of our sensors. Euro-Gas accepts no liability for any consequential losses, injury or damage resulting from the use of this document, the information contained within or from any omissions or errors here in. This document does not constitute an offer for sale and the data contained is for guidance only and may not be taken as warranty. Any use of the given data must be assessed and determined by the user there of to be in accordance with federal, state and local laws and regulations. All specifications outlined are subject to change without notice.



**EURO-GAS MANAGEMENT SERVICES LTD, CHURSTON HOUSE,
BASCOMBE ROAD, CHURSTON FERRERS, DEVON, TQ5 0JJ, UK**

☎: +44 (0)1803 844414

sales@euro-gasman.com

www.euro-gasman.com

EURO-GAS
MANAGEMENT SERVICES LTD

VER 2606