

H2 SS SENSOR – MICRO SOLID STATE HYDROGEN 5% VOLUME



FEATURES

- Micro size ideal for portable, fixed, wireless and digital gas detection applications
- High sensitivity, fast response with low noise
- Solid state long lifetime technology of greater than 5 years without risk of leakage
- Extreme linear response
- No poisoning
- Typical warm up time in seconds
- nA power consumption
- No zero line drift
- Wide temperature range with excellent sensitivity at low temperatures
- Low or no cross-interference with other environmental gases
- Lower detection limit of 10ppm and high overload range of 20% vol H2

TYPICAL APPLICATIONS

- Hydrogen Leakage & Safety Monitoring
- Hydrogen Monitoring in Battery Rooms
- Environmental Monitoring
- Hydrogen Industrial Plants
- Process Monitoring
- Energy Engineering

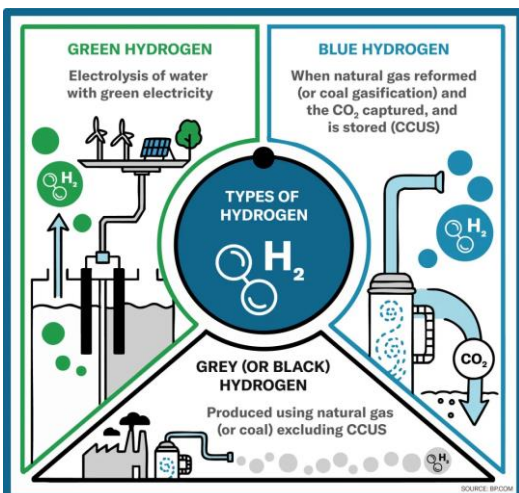

H2 SS SENSOR – MICRO SOLID STATE HYDROGEN 5% VOLUME

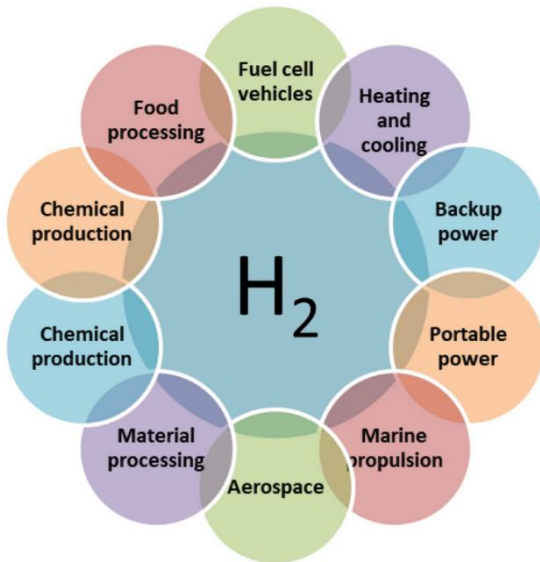
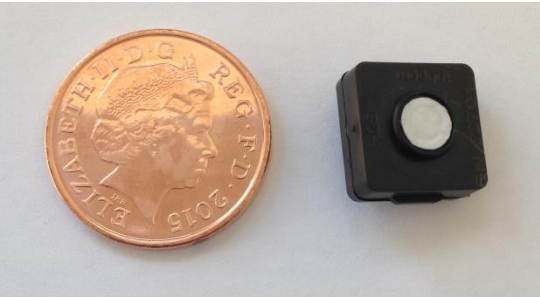

SPECIFICATION

Measuring Principle:	Amperometric, 3-electrode sensor
Detectable Gases:	Hydrogen H ₂
Standard Range:	0 – 5% volume (50,000ppm) H ₂
Optional Ranges on request:	0-1000ppm, 0-5000ppm, 0-20,000ppm (2% vol) H ₂
Maximum Over-Range:	> 20% volume (expected)
Sensitivity:	0.2 ± 0.1 nA/ppm
Zero current at normal conditions:	± 3 nA Measured value for zero current depends on potentiostat electronics.
Response Time (T₅₀):	< 35 seconds
Response Time (T₉₀):	< 90 seconds
Sensor Warm-Up Time:	< 60 seconds
Repeatability:	1.5 % typically
Resolution (16 Bit ADC):	0.001% volume (10ppm) Minimum recommended resolution for a 16Bit ADC.
Lower Detectable Limit (LDL):	0.001% volume (10ppm)
Linearity:	Linear
Long-Term Sensitivity Drift:	< 5% / year Long-Term drift may vary depending on storage conditions, application, environment and usage.
Expected Operating Life:	> 5 years

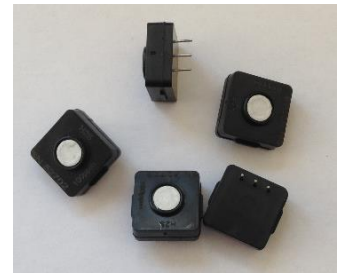
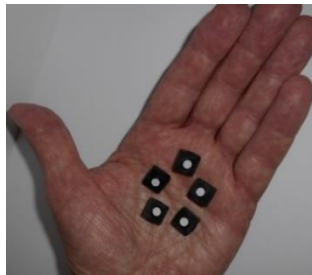

H2 SS SENSOR – MICRO SOLID STATE HYDROGEN 5% VOLUME

SPECIFICATION

Operating Temperature Range:	-40°C to +55°C
Humidity Range (non-condensing):	15 – 95% RH
Pressure Range:	800 to 1200 HPa
Bias Voltage:	0 mV
Recommended Load Resistor:	100 Ω
Zero Drift in Clean Air:	< 0.001% volume
Storage Temperature:	0°C to +20°C (optimum 4°C to 6°C)
Storage Conditions:	12 months in original container
Housing Material:	PPO
Weight:	< 0.7g
Sensor Dimensions:	12.5mm x 11.5mm x 9mm
Warranty Period:	12 months from date of manufacture
Part Number:	2112B012710

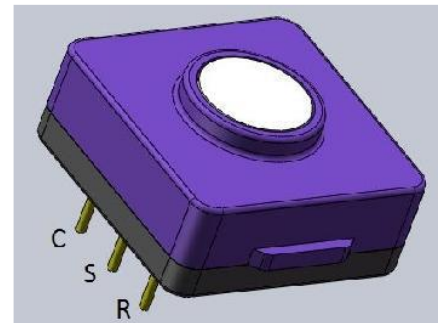

DIMENSIONS

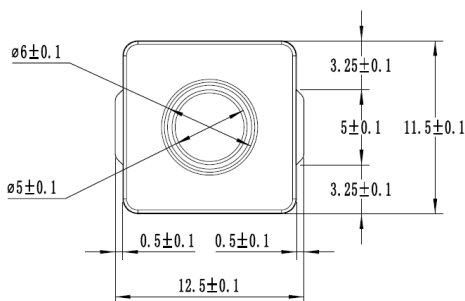

Top

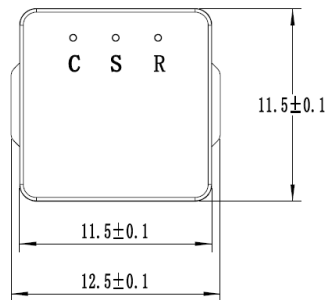

Bottom

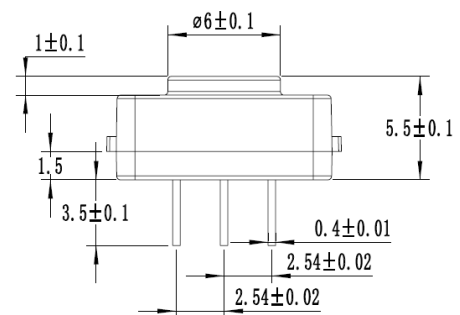

All dimensions are in mm. Tolerances are +/- 0.10mm unless otherwise stated.

Note: PCB sockets are recommended for the sensor pin connection. Soldering or using glue with the sensor should be avoided and will invalidate warranty.



H2 SS SENSOR – MICRO SOLID STATE HYDROGEN 5% VOLUME

TEMPERATURE CURVE

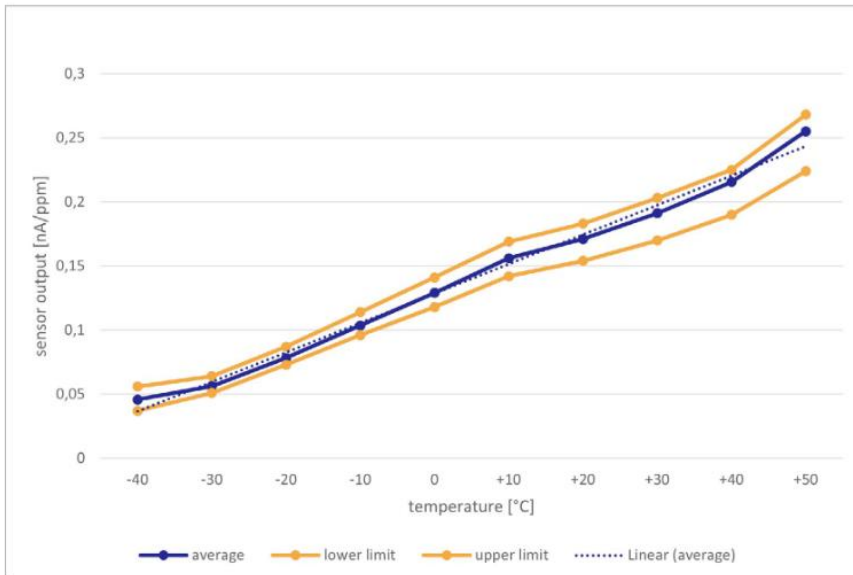

ACCESSORIES



Precision SIP terminals
for sensor pin connection,
part no. 2112B4503330



**Test and calibration
gas flow cap**, part no.
2112B013701



SS Micro TX
UART or i2c miniature
precalibrated pluggable
transmitter, part no.
2112B0127104



SS PCB
Voltage and i2c miniature precalibrated
pluggable transmitter, with onboard
temperature measurement and life test
capability, part no. 2112B019900



H2 SS SENSOR – MICRO SOLID STATE HYDROGEN 5% VOLUME

CROSS SENSITIVITY DATA

GAS	TEST CONCENTRATION	CALCULATED TEST CONCENTRATION	READING IN PPM
Ammonia NH ₃	100ppm	1ppm	0ppm
Benzene C ₆ H ₆	- reaction not expected -	1ppm	0ppm
Carbon Dioxide CO ₂	- reaction not expected -	10% vol	0ppm
Carbon Monoxide CO	100ppm	100ppm	100ppm
Ethanol C ₂ H ₆ O	20ppm	1ppm	0ppm
Ethylene C ₂ H ₄	200ppm	1ppm	0ppm
Ethylene Oxide C ₂ H ₄ O	-	1ppm	0ppm
Isobutane C ₄ H ₈	-	1ppm	0ppm
Methane CH ₄	300ppm	1% vol	0ppm
Methyl Mercaptan CH ₄ S	10ppm	1ppm	0ppm

The 'Test Concentration' is used to test the sensor. The 'Sensor Reading' applies to the amount of the 'Calculated Test Concentration'.

Sensor performance is temperature dependent. All performance specifications are based on test conditions with new sensors with the following environment conditions: +25°C, 50% relative humidity, 1 atm (1013 mBar or ambient pressure), flow rate > 150qcm/min. Cross-sensitivity gases are not target gases. Relationship can change overtime.

Whilst the SS sensor is designed to be highly specific to the gas it is intended to measure, it will still respond to some degree to various gases. The table is not exclusive and other gases not included in the table may still cause a sensor to react.

The cross-sensitivity values quoted are based on tests conducted on a small number of sensors. They are intended to indicate sensor response to gases other than the target gas. Sensors may behave differently with changes in ambient conditions and any batch may show significant variation from the values quoted.

The figures in this table are typical values and should not be used as a basis for cross calibration. Cross sensitivities may not be linear and should not be scaled. For some cross interference, break through might occur if gas is applied for a longer time period.

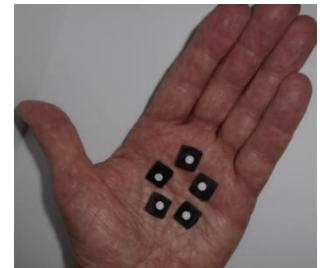

Notes: PCB sockets are recommended for the sensor pin connection. Soldering or using glue with the sensor should be avoided and will invalidate warranty. Socket connector information available on request. Sensors are designed to operate in a wide range of harsh environments and conditions. However, it is important to avoid exposure to high concentrations of solvent during storage, fitting into instrumentation and operation. When using sensors on PCBs, degreasing agents should be used prior to the sensor being fitted.

By the nature of the technology used, any sensor can potentially fail to meet specification without warning. Euro-Gas makes every effort to ensure reliability of all sensors but where life safety is a performance requirement of the product and, where practical, Euro-Gas recommends that all gas sensors and instruments using sensors are checked for response to gas before use. The data contained in this document is believed to be accurate and reliable. The data given is for guidance only. Euro-Gas Management Services Ltd accepts no liability for any consequential losses, injury or damage resulting from the use of this datasheet or the information contained in it. Customers should test the sensors under their own conditions to ensure that the sensors are suitable for their own requirements and in accordance with the plans and circumstances of the specific project and any standards/regulations pertaining to the country in which the sensors will be utilised. Performance characteristics on this data sheet outline the performance of newly supplied sensors. Output signal can drift below the lower limit over time. This datasheet is not intended to form the basis of a contract and in the interest of product improvement, Euro-Gas reserves the right to alter design features and specifications without notice. 2502

