

SENSOR SPECIFICATION SHEET

4-NH3-100M TX

Ammonia NH3 Gas Sensor in 4 Series Size
with precalibrated 4-20mA Transmitter TX Board



Applications

- Leak & Safety Detection
- Discontinuous Measurement
- For Portable & Fixed Gas Detectors



Measurement

Operation Principle	3-Electrode Electrochemical
Nominal Range	0 - 100 ppm
Maximum Overload	200 ppm
Inboard Filter	-
Output Signal	110 ± 30 nA/ppm
Resolution (Electronics dependent)	< 0.5 ppm
T90 Response Time	< 35 s
Typical Baseline Range (pure air, 20°C)	-3 ppm to 3 ppm
Maximum Zero Shift (+20°C to +40°C)	see Graph
Repeatability	< 3% of signal
Output Linearity	< 5 % full scale
Gain (Only applies to 4-Electrode sensors)	-

Electrical

Rec. Load Resistor	10 - 33 Ω
Bias (V_Sens-V_Ref)	not allowed
Conformity to RoHS directive	RoHS Compliance

Environmental

Relative Humidity Range	15 % to 90 % RH non-condensing
Temperature Range	-10 °C to 50 °C
Pressure Range	Atmospheric ± 10%
Pressure Coefficient	N.D.
Humidity Effect ¹⁾	< 4 ppm

1) Abrupt changes in rel. humidity causes a short-term transient signal.

SENSOR SPECIFICATION SHEET

4-NH3-100M TX

Ammonia NH3 Gas Sensor in 4 Series Size
with precalibrated 4-20mA Transmitter TX Board



Lifetime

Expected Operation Life	2 years in air
Expected Long Term Output Drift in air	< 5 % signal loss per 6 months
Filter Life	
Storage Life	3 months in original container
Rec. Storage Temperature	5°C - 20°C
Warranty Period	12 months from date of manufacture

Performance data recorded at 20 – 25 °C, 30 - 50% RH, 900 - 1100 mbar

BOTTOM VIEW

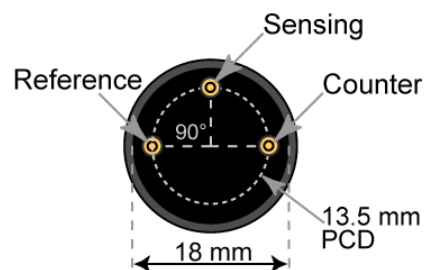

SIDE VIEW

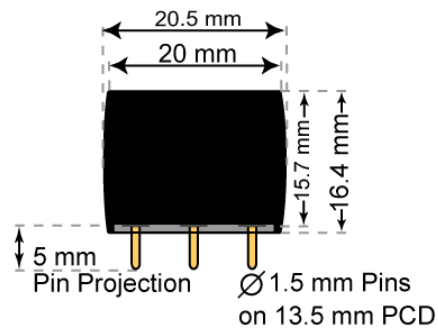

± 0.10 mm

Mechanical

Weight	5.5 g
Orientation	Any
Housing material	Polycarbonate

SENSOR SPECIFICATION SHEET

4-NH3-100M TX



Ammonia NH3 Gas Sensor in 4 Series Size
with precalibrated 4-20mA Transmitter TX Board

Cross Sensitivity Data The table below does not claim to be complete. Interfering gases should not be used for calibration.

Interfering Gas	Concentration [ppm]	Reading [ppm]
Cl ₂	20	-55
CO	300	0
CO ₂	20000	0
H ₂	200	0
H ₂ S	20	7
NO	20	-1
NO ₂	20	-20
SiH ₄	10	0
SO ₂	20	-7

Important Application Notes: Long term exposures and high concentrations of SO₂, H₂S, NO, NO₂ can affect the performance characteristics.

Temperature dependence

The output of an electrochemical sensor varies with temperature. The graph below shows the temperature dependent variation of baseline and sensitivity respectively. The results shown here are raw data (batch average) without any post-processing steps. The sensitivity and baseline are referenced to the signal at 20°C (reference point). Please note: It is highly recommended to acquire the temperature dependence curves with the whole instrument. The sampling system, the humidity, the electronics and the interaction between the electronics and the sensor have a significant impact on the temperature dependence of the final measurement reading.

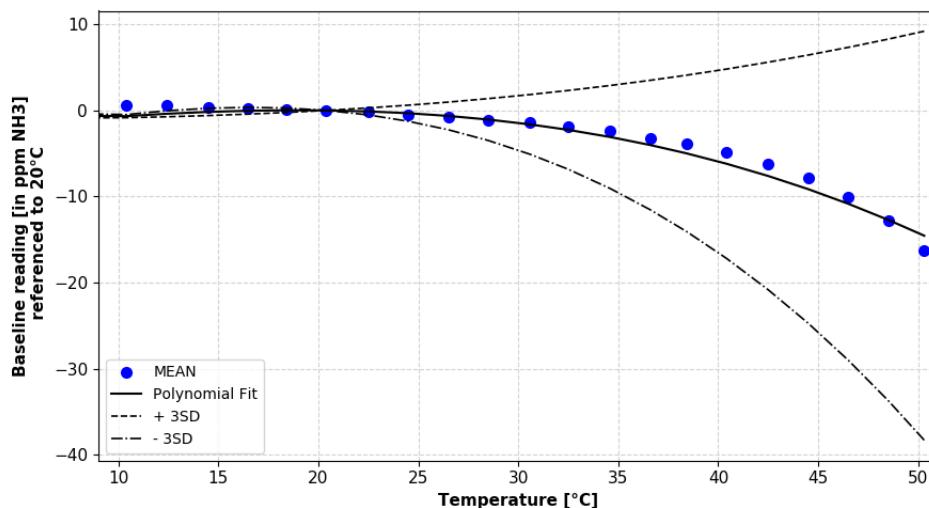

Baseline shifted with respect to reference point at 20°C.

4-20 mA Transmitter Board for Electrochemical Gas Sensors

Suitable for 4 Series Size Sensors

Application

These analogue transmitter boards are suited for measurements **in ppm to low % levels** (nominal range > 5 ppm) but not for ppb level measurements. The boards are provided precalibrated and configured according to the output and type of gas sensor used. Transmitter boards for gas sensors requiring a bias voltage are equipped with an additional potentiometer.

Technical specifications

Supply voltage	12 – 36 VDC ¹
Output at zero gas concentration	4 mA (40 mV)
Output at full-scale	20 mA (200 mV)
Sockets plating	Gold
Compliance	RoHS-compliant
Weight	~ 18 g

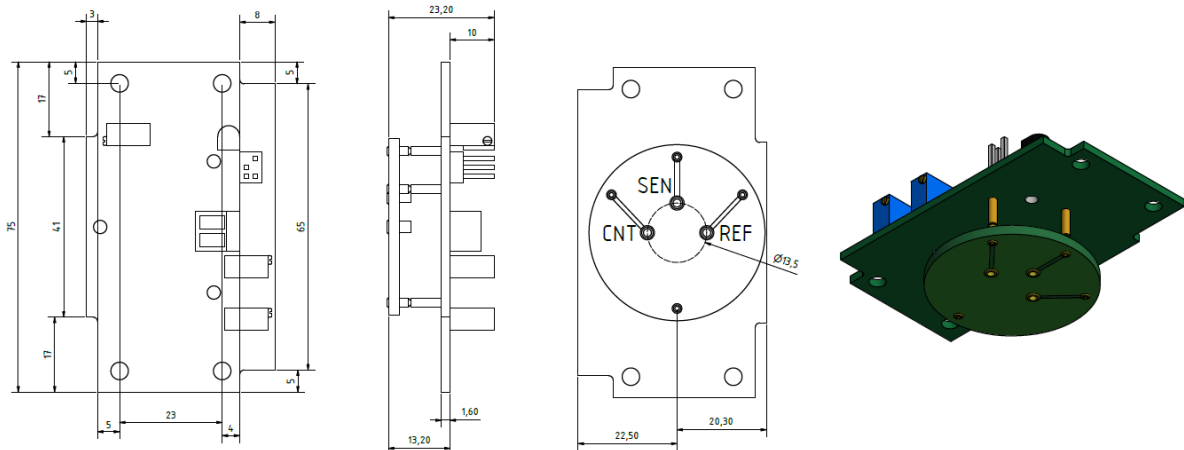

Fig. 1: Transmitter dimensions

¹ For sensors requiring a bias voltage the transmitter supply voltage should always be > 12 VDC.

Operating transmitter with voltage output

Note: Pay attention to the correct polarity to avoid damaging the transmitter!

Connect the supply voltage to the connector (V/C) and the transmitter becomes immediately operable. On unpowered transmitter boards, connected sensors will be short-circuited between sensing and reference electrode. This does not only apply to transmitter boards for sensors with bias voltage.

The voltage output signal can be measured between pins 1 and 2. The output signal has a linear range from 40 mV and 200 mV respectively.

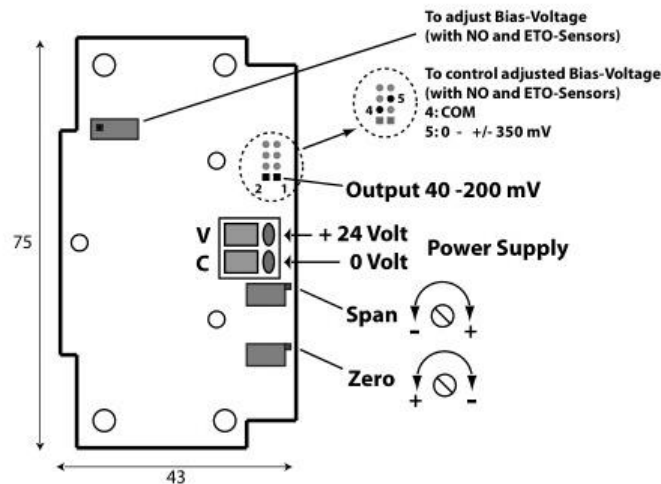

Fig. 2: Operating transmitter with voltage output. For illustration purposes, a supply voltage of +24 VDC is used.

Operating transmitter in current mode

The transmitter can be operated in a 2-wire mode. The drawn current (4-20 mA) is proportional to the sensor signal. This setup is widely used in (multi-channel) gas detectors.

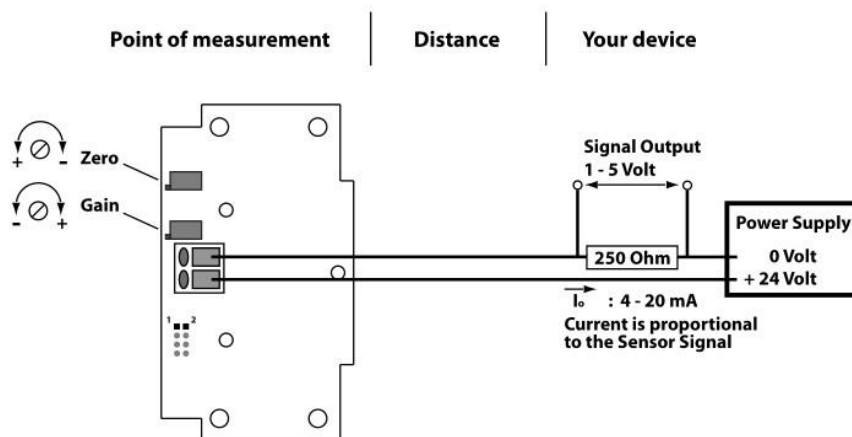

Fig. 3: Operating transmitter in current mode. For illustration purposes a supply voltage of +24 VDC and a load resistor of 250 Ω are used.

Calibration

General recommendations

- **Flow rate:** The gas flow rate strongly depends on the geometry and construction (volume, materials) of the gas sampling system. For calibrations we recommend using a flow rate of 300 – 1000 ml/min.
- **Calibration gas:** For the most accurate calibration results, the target gas must be used. In the case a surrogate is used, please refer to the cross-sensitivity table in sensor data sheet. Note that the value depicted in the cross-sensitivity table in the sensor data sheets represent average values recorded across many sensor batches. For an individual sensor, the value can vary.
- **Conditions:** We recommend performing the calibrations at 20°C, a relative humidity range of 30 – 50% and standard atmospheric pressure.

Procedure

1. Remove the short-cutting spring mounted on the outside of the sensor. Sensors requiring a bias-voltage are delivered without such a spring. Plug the sensor onto the transmitter board.
2. To obtain an accurate zero point of 40 mV (4 mA), the potentiometer zero must be adjusted accordingly. We recommend purging the sensor with synthetic air for at least 3 minutes and then adjust the zero line.
3. The amplification is adjusted when the target gas is applied to the sensor. Use at least 50% of the sensor's full-scale concentration to obtain an accurate result. The table below shows the expected output signal depending on the target gas concentration with respect to the full-scale of the sensor:

Target gas concentration w.r.t to full-scale of sensor [%]	Transmitter output voltage [mV]	Transmitter output in 2-wire mode [mA]
50	120	12.0
60	136	13.6
70	152	15.2
80	168	16.8
90	184	18.4
100	200	20.0

Transmitter output as a function of the target gas concentration w.r.t to the sensor's full-scale in %.



Transmitter configuration

General configuration

The code is composed of two letters and two numbers.

- Position 1: **N** (normal), **B** (+300 mV bias) or **L** (+50 mV bias)
- Position 2: **1** ($R_{load} = 10 \Omega$) or **3** ($R_{load} = 33 \Omega$)
- Position 3: **X** (oxidation) or **R** (reduction)
- Position 4: Amplification **1**, **2** (basic configuration), **3** or **4**

Coding of amplification

The maximal amplification G is where the potentiometer *span* is fully turned clockwise. The maximal current i_{max} is the current a given sensor produces at its full-scale concentration. **The amplification factors were determined for oxidation configurations.** Slight variations can occur for the reduction configuration.

Code	Max. amplification factor G	For max. sensor current i_{max} [μA]
1	600	150 – 700
2	1600	16 – 220
3	10000	13 – 30
4	11000	2 - 25

Amplification factors for oxidation configuration with corresponding i_{max} and number code.

Example

An H₂S 200ppm sensor has a specified sensitivity of 370 ± 80 nA/ppm and a nominal full-scale range of 200 ppm. Therefore, $i_{max} = (370 \text{ nA/ppm}) \cdot (200 \text{ ppm}) = 74 \mu A$ which would result in a recommended transmitter configuration N3X2.

Notes: Sensors are designed to operate in a wide range of harsh environments and conditions. However, it is important to avoid exposure to high concentrations of solvent during storage, fitting into instrumentation and operation. When using sensors on PCBs, degreasing agents should be used prior to the sensor being fitted. By the nature of the technology used, any sensor can potentially fail to meet specification without warning. Euro-Gas makes every effort to ensure reliability of all sensors but where life safety is a performance requirement of the product and, where practical, Euro-Gas recommends that all gas sensors and instruments using sensors are checked for response to gas before use.

The data contained in this document is believed to be accurate and reliable. The data given is for guidance only. Euro-Gas Management Services Ltd accepts no liability for any consequential losses, injury or damage resulting from the use of this datasheet or the information contained in it. Customers should test the sensors under their own conditions to ensure that the sensors are suitable for their own requirements and in accordance with the plans and circumstances of the specific project and any standards/regulations pertaining to the country in which the sensors will be utilised. Performance characteristics on this data sheet outline the performance of newly supplied sensors. Output signal can drift below the lower limit over time. This datasheet is not intended to form the basis of a contract and in the interest of product improvement, Euro-Gas reserves the right to alter design features and specifications without notice. 2306

