

4-COS-100 CARBONYL SULFIDE SENSOR 0-100PPM COS

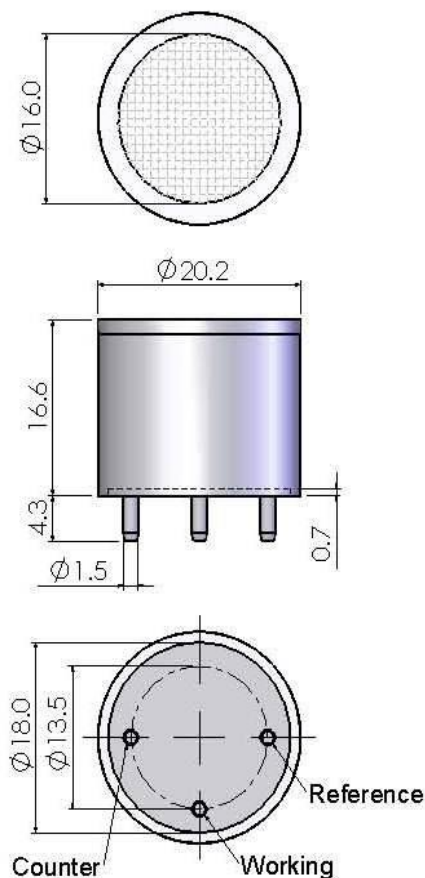

Outline Dimensions



All dimensions are in millimeters.
All tolerances are ± 0.2 mm.

Note: PCB sockets are recommended for the sensor pin connection. Soldering to the sensor should be avoided and will invalidate warranty.

All performance specifications are based upon the following environment conditions: +20°C, 50% relative humidity and 1 atm (1013 mBar or ambient pressure).

SPECIFICATION – 4 SERIES

Operating Principle:	Electrochemical, 3-electrode cell
Gas Detected:	Carbonyl Sulfide COS
Measurement Range:	0 – 100 ppm
Resolution:	< 1 ppm
Expected Operating Life:	24 months in air
Temperature Range:	- 30°C to + 50°C
Humidity Range (non-condensing):	15 – 90% RH
Response Time (T90):	\leq 45 seconds
Long Term Sensitivity Drift:	< 2% signal per month
Linearity at Standard Range:	Linear
Sensitivity:	200 +/- 100 nA/ppm
Repeatability:	< +/- 2% signal
Pressure range:	800 to 1200 mbar
Bias Potential:	300 mV
Recommended Load Resistor:	5 ~ 50 Ω
Warranty Period:	18 months from date of manufacture
Storage Life:	6 months in sealed container
Storage Temperature:	0°C to +20°C
Weight (approx):	5 g
Orientation Sensitivity:	None
Part Number:	2112B21510215



4-COS-100 CARBONYL SULFIDE SENSOR 0-100PPM COS

CROSS SENSITIVITY DATA

Gas	Concentration (ppm)	Output Signal (ppm COS equivalent)
Carbon Monoxide CO	50	50
Chlorine Cl ₂	8	0
Hydrogen Sulphide H ₂ S	25	0
Nitrogen Dioxide NO ₂	10	0
Nitric Oxide NO	20	0
Sulphur Dioxide SO ₂	10	0

Notes: Calibration with cross-sensitivity gas is not recommended. It is recommended to calibrate an instrument using the target gas for accurate measurements.

Cross-sensitivities are supplied as a guidance only and do not form part of the product or datasheet specification.

Cross-sensitivities may fluctuate between +/- 50% and may show significant variation from batch to batch and within the sensor's lifetime. Values quoted are based on tests conducted on a small number of sensors and any batch may show significant variation. The cross-sensitivities are including but not limited to the above gases. The sensor may also respond to other gases and may behave differently with changes in application and environmental conditions.

Notes: Sensors are designed to operate in a wide range of harsh environments and conditions. However, it is important to avoid exposure to high concentrations of solvent during storage, fitting into instrumentation and operation. When using sensors on PCBs, degreasing agents should be used prior to the sensor being fitted.

By the nature of the technology used, any sensor can potentially fail to meet specification without warning. Euro-Gas makes every effort to ensure reliability of all sensors but where life safety is a performance requirement of the product and, where practical, Euro-Gas recommends that all gas sensors and instruments using sensors are checked for response to gas before use.

The data contained in this document is believed to be accurate and reliable. The data given is for guidance only. Euro-Gas Management Services Ltd accepts no liability for any consequential losses, injury or damage resulting from the use of this datasheet or the information contained in it. Customers should test the sensors under their own conditions to ensure that the sensors are suitable for their own requirements and in accordance with the plans and circumstances of the specific project and any standards/regulations pertaining to the country in which the sensors will be utilised.

Performance characteristics on this data sheet outline the performance of newly supplied sensors. Output signal can drift below the lower limit over time. This datasheet is not intended to form the basis of a contract and in the interest of product improvement, Euro-Gas reserves the right to alter design features and specifications without notice. 02/22

