

GasSense NDIR User Manual

INDEX

INDEX	1
1. OVERVIEW	2
2. TECHNICAL DATA	3
3. SPECIFICATIONS	4
4. PRODUCT DESCRIPTION	5
4.1 Mechanical details	5
4.2 Piping.....	7
4.3 Connections	7
5. INSTALLATION	10
6. CALIBRATION PROCEDURE	10
7. MAINTENANCE	11
8. WARRANTY AND LIMITATIONS OF LIABILITY	11



GasSense NDIR User Manual

1. OVERVIEW

The GasSense NDIR gas sensor, with integrated transmitter, is an innovative measurement module for the detection of CO₂, CO, N₂O, CH₄ or related hydrocarbons. The sensor can be easily integrated as an OEM component into controls, measurement systems and monitoring instruments.

The sensor uses dual channel Non-Dispersive Infrared Detection (NDIR) and detects the net increase or decrease of light that occurs at the wavelength where absorption of the detecting gas takes place. The light intensity is then correlated to gas concentrations.

To ensure a reliable and stable measurement, the module is temperature compensated. The gas cell has been designed using non-sequential ray tracing techniques in order to ensure the best compromise between accuracy and sensor dimensions.

Additionally, a dedicated rugged gas sensor cell option is available to minimise corrosive effects in harsh industrial environments, like biogas applications. The GasSense electronic board features a native wireless module managed with Ultra Low Power techniques, a fault diagnostics system and a power module suited to manage charging and energy recovery systems. The GasSense sensor can be used with a pneumatic pump or can simply work by natural diffusion mode.



GasSense NDIR

User Manual

2. TECHNICAL DATA

Detection Method	Dual channel Non-Dispersive Infrared (NDIR)		
Dimensions	Depending on the sensor model (type of gas and range, see §5.1)		
Source drive frequency	1 to 2Hz		
Data refresh rate	5 to 10 seconds		
Response time (t90)	15 to 40s @ 20°C ambient and @ 1 l/min		
Warm up time	<30s @ 20°C operational, <30 minutes @ 20°C (full spec)		
Operating conditions	Temperature 0°C to 50°C linear compensated		
	Humidity 0-95% RH (non-condensing) not compensated		
	Pressure 800-1150hPa not compensated		
Pressure dependency	+1.5% reading per kPa deviation from normal pressure of 100kPa		
Storage temperature	-40°C to 85°C		
Analog Output	4-20mA, 0-5V		
Analog Input	2 available for third-party devices		
Digital I/O	4OUT: Open collector, ground referred, protected; 4 IN: 0-5 V protected up to 24Vdc		
Connector type		On module connector	Mating connector
	Power Supply:	Weidmüller SL3.5/2/180G3.2	Weidmüller BL3.5/2
	Analog I/O:	Weidmüller SL3.5/2/180G3.2	Weidmüller BL3.5/6
	Pump:	Weidmüller SL3.5/2/180G3.2	Weidmüller BL3.5/2
	Digital I/O:	TE Connectivity 215307-5	TE Connectivity 826656-5
	Analog Out (0-5V):	TE Connectivity 8-215464-6	TE Connectivity 8-215079-6
	Power Supply & UART TTL level (0-5V) (J20):	TE Connectivity 7-215464-6	TE Connectivity 7-215079-6
Pipe connections	For tube with diameter $\varnothing 4 / \varnothing 2.5\text{mm}$		
Recommended Flow Rate	0.5 l/min		
Interface connection	UART (TTL level 0-5V), baud rate: 9600 (default) - 19200 - 38400		
MTBF	> 5 years		
Long Term Drift	< 2% of FS range / year		
Power supply	9-24V DC, reverse protected		
Power consumption	max 90mA @ 9VDC, excluding pump power absorption		



GasSense NDIR User Manual

3. SPECIFICATIONS

Gas	Measurement Range*	Accuracy**	Zero Res. (ppm)	Full Scale Res.	Zero Repeatability (ppm)	Full Scale Repeatability (ppm)	GasSense Model
CO ₂	0-1000ppm	±1% FS	1	1% FS	±5	±10	A-7
	0-2000ppm	±1% FS	1	1% FS	±10	±25	A-8
	0-5000ppm	±1% FS	1	2% FS	±10	±50	A-1
	0-1%	±2% FS	1	2% FS	±25	±200	A-9
	0-5%	±2% FS	1	2% FS	±25	±250	A-6
	0-10%	±2% FS	1	2% FS	±25	±250	A-2
	0-25%	±2% FS	1	1% FS	±50	±500	A-3
	0-100%	±1% FS	1	1% FS	±1000	±5000	A-4
	0-100% biogas ***	±1% FS	1	1% FS	±1000	±5000	A-4l
	CO	0-2000ppm	±1% FS	5	1% FS	±10	±70
0-2%		±1% FS	5	1% FS	±10	±70	B-2
CH ₄	0-2000ppm	±4% FS	5	4% FS	±15	±100	C-1
	0-100% LEL	±2% FS	15	4% FS	±50	±500	C-2
	0-100% vol. biogas ***	±2% FS	500	2% FS	±1000	±5000	C-3l
	0-100% vol.	±2% FS	300	2% FS	±500	±3000	C-4
HC ****	0-2000ppm	±4% FS	5	4% FS	±15	±100	D-1
	0-100% LEL	±2% FS	15	4% FS	±50	±500	D-2
N ₂ O	0-100ppm	±2% FS	1	2% FS	±3	±3	F-3
	0-1000ppm	±1% FS	1	1% FS	±10	±20	F-2
	0-2000ppm	±1% FS	1	1% FS	±10	±20	F-1
	0-2000ppm Diffusion	±1% FS	1	1% FS	±10	±20	F-6
	0-100% vol	±2% FS	1	2% FS	±1000	±5000	F-5

* Other measurement ranges available on special request.

** Stated accuracy excludes calibration gas tolerance of ± 1%.

*** Anti-Corrosion sensor cell and housing model.

**** Currently available with Propane or Hexane calibration – other hydrocarbons on special request.



EURO-GAS MANAGEMENT SERVICES LTD, CHURSTON HOUSE,
BASCOMBE ROAD, CHURSTON FERRERS, DEVON, TQ5 0JJ, UK

☎: +44 (0)1803 844414 Fax: +44 (0)1803 844224

sales@euro-gasman.com

www.euro-gasman.com

EURO-GAS
MANAGEMENT SERVICES LTD

GasSense NDIR User Manual

4. PRODUCT DESCRIPTION

The GasSense combines an electronic circuit board and a measurement gas chamber, connected to the board with two connectors. The dimensions of the gas chamber vary depending upon the model and two input and output connectors are provided. The GasSense is provided with firmware to manage the measuring cycle (gas inlet through pneumatic pump and gas concentration calculation), temperature compensation and communication. The working frequency and other parameters can be modified according to customer requirements. Please contact Euro-Gas for details.

4.1 Mechanical details

The GasSense transmitter board, common to all models, is 56mm x 48mm wide. Three holes (shown in black in the drawing below) allow the board to be secured according to customer requirements:

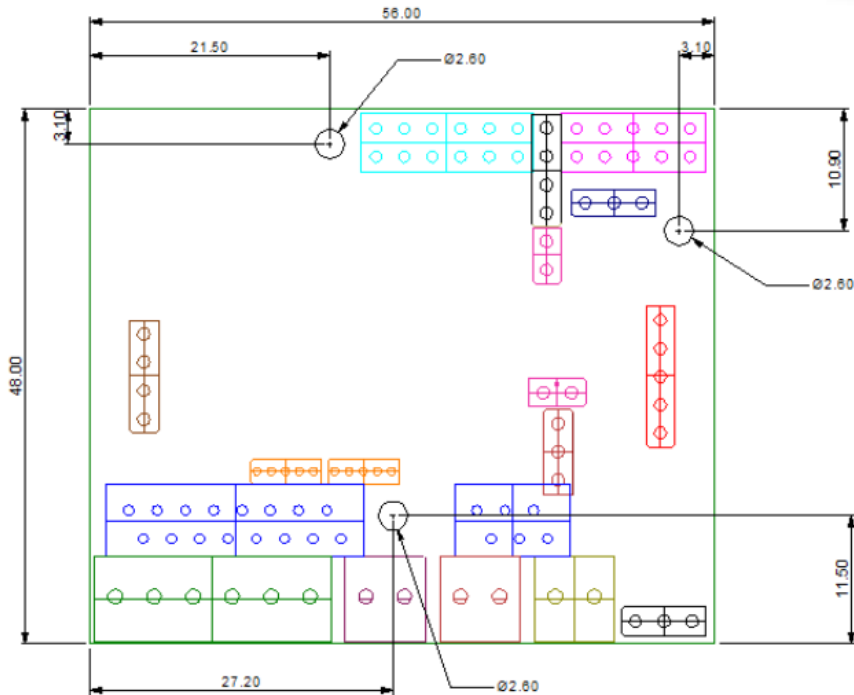

GasSense NDIR User Manual

GasSense NDIR sensor dimensions vary depending on the sensor model (appropriate to the type of gas and range required):

Models: A-1, A-2, A-4, A-4I, A-6, A-7, A-8, A-9, C-2, C-3I, C-4, D-2, F-5 (see below):

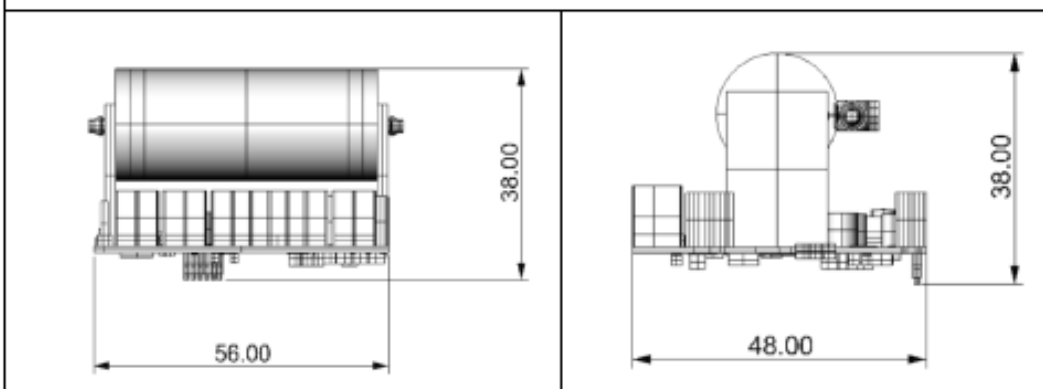

Models: B-1, B-3, B-4, B-5, C-1, C-6, D-1, F-1, F-3, F-6 (see below):

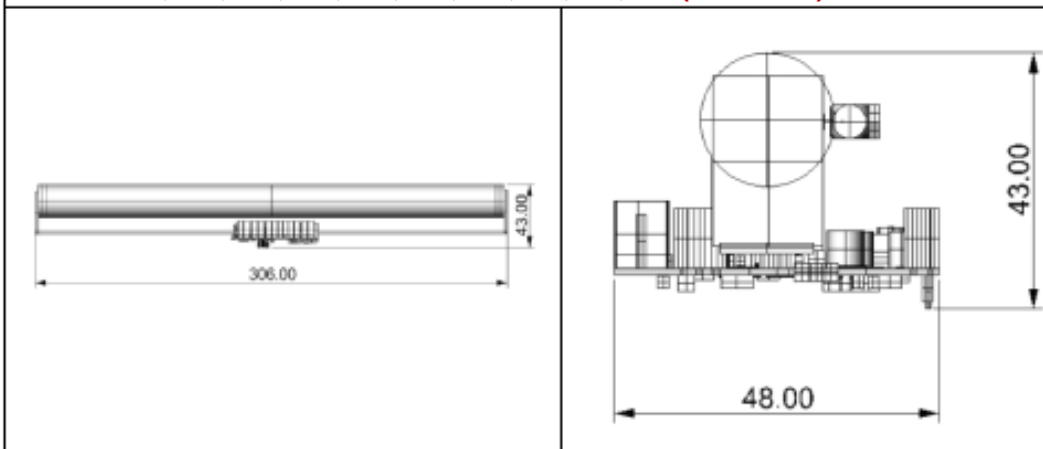

Model: A-3 (see below):

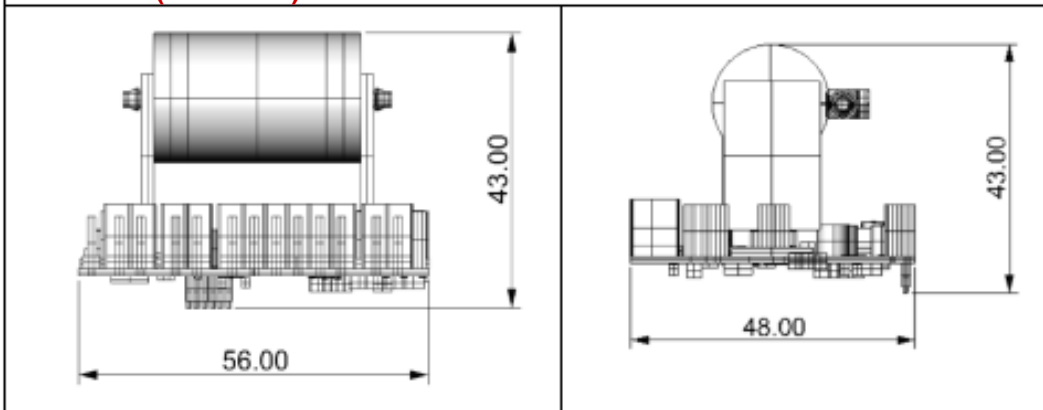

GasSense NDIR User Manual

4.2 Piping

The GasSense NDIR sensor has two connections available for pipe connections. The sensor performs best if the gas flows in a controlled direction inside the gas cell. Looking at the GasSense sensor from the top, with the WEIDMULLER (orange) connectors positioned at the bottom, the connector on the right side is the gas inlet and the connector on the left side is the gas outlet. The following diagram shows the gas inlet/outlet position in relation to the gas cell and orange connectors. Connectors vary according to the GasSense sensor model.

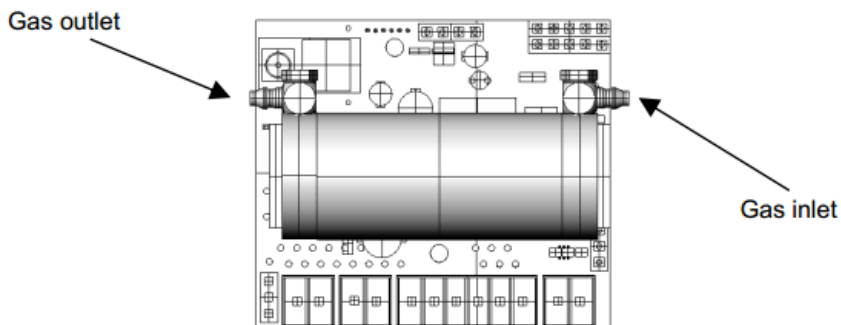

4.3 Connections

The diagram below shows the top layer of the GasSense board and the board terminals. Terminals vary depending on the version and some may not be mounted or functioning.

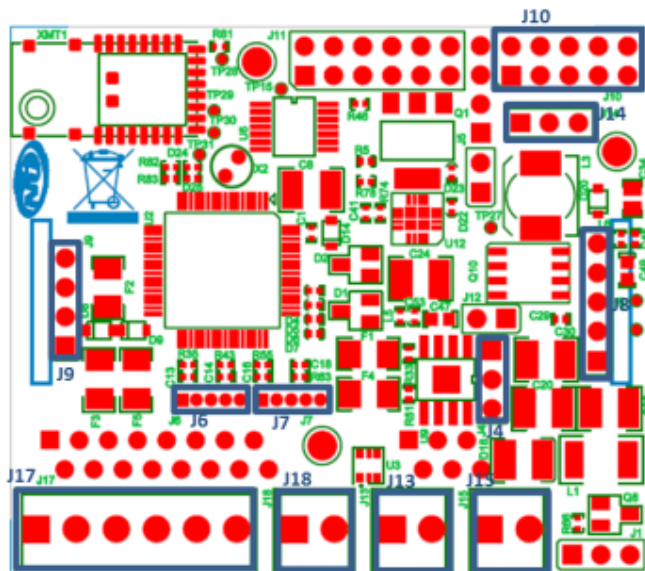

GasSense NDIR

User Manual

4.3 Connections (continued)

Connector	Function
J4	Jumper for power supply selection
J6	SPI bus interface
J7	SPI bus interface
J8	Source
J9	Detector
J10	Digital I/O Pin1, 3, 5, 7: IN (0-5V protected up to 24Vdc) Pin2, 4, 6, 8: OUT (Open collector, ground referred, protected) Pin9, 10: gnd
J13	Power supply. Solar panel input Pin1: plus (+); Pin2: gnd
J14	Power supply. Battery input Pin1: pack thermistor; Pin2: gnd; Pin3: plus (+)
J15	Power supply. 9-24V DC Pin1: plus (+); Pin2: gnd
J17	Analog output (4-20mA; 0-5V), two analog inputs (4-20mA or 0-5V) Pin1: 0-5V; Pin2: 4-20mA; Pin3: gnd; Pin4: analog input (+); Pin5: analog input (+); Pin6: gnd
J18	Pneumatic pump power supply Pin1: plus(+); Pin2: minus (-)



GasSense NDIR User Manual

4.3 Connections (continued)

The diagram below shows the bottom layer of the GasSense board and highlights the available connectors:

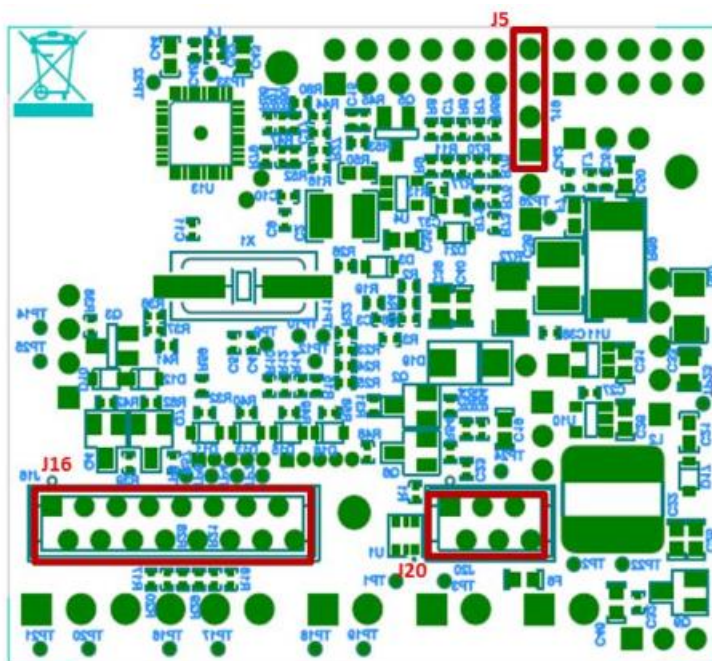

Connector	Function
J5	UART 9600-115200 Baud (0-3V TTL level) Pin1: Tx Pin2; Pin4: gnd Pin3: Rx
J16	Analog output (0-5V) Pin10: 0-5V; Pin9: gnd
J20	Power supply 0-24V DC; UART TTL level (0-5V) required 0-5V external power supply Pin1: ext UART supply; Pin2: 9-24VDC; Pin3: Tx UART; Pin4: Rx UART; Pin5: nc; Pin6: gnd



GasSense NDIR User Manual

4.3 Connections (continued)

Notes:

- The DC power input is protected against reverse, over-voltage (up to 33V) and short circuit (max absorption 250mA).
- The external pump power supply is by default 3V (5V optional) and the max power absorption is 160mA.
- J17 connector: there are two analogue input 4-20mA (0-5V optional).
- Digital input are protected against over-voltage (up to 35V) and short circuit (max absorption 250mA).
- Digital output are protected against short circuit (max absorption 160mA).
- Use rechargeable batteries (Ion-Li 7.4V with NTC thermistore).
- Tyco connectors are available on the board bottom layer. They are used for board power supply (9-24V protected against reverse, over-voltage (up to 33V) and short circuit (max absorption 250mA), UART TTL level (0-5V) serial bus, 5V DC power supply for the UART, analogue output 0-5V.

5. INSTALLATION

The GasSense sensor is factory calibrated and ready for use directly after power up. There are 3 alternative ways to power supply the sensor board:

1. Using the J15 terminal for DC voltage input
2. Using the J14 terminal for battery input
3. Using the J20 terminal for DC voltage input

6. CALIBRATION PROCEDURE

Please refer to the Calibration Procedure document. Please discuss your application with us for advice on calibration.



GasSense NDIR

User Manual

7. MAINTENANCE

The GasSense sensor is maintenance free under normal conditions. The sensor is a safety device and must only be repaired by the manufacturer. Do not modify the sensor and do not reconstruct it. It might otherwise no longer measure the gas concentration reliably.

8. WARRANTY AND LIMITATIONS OF LIABILITY

Euro-Gas grants a warranty for this device for a period of 12 months from commissioning, documented by a commissioning report. Within this warranty period, we will at our discretion repair or replace the device free of charge if found to be defective as to workmanship or material.

The warranty excludes: damages attributable to improper use, normal wear and defects that have only a negligible influence on the device's value or suitability for use.

Liability for the functioning of the sensor shall pass at all events to the owner or operator if the sensor is improperly maintained or repaired or if it is used other than for its intended purpose. Euro-Gas accepts no liability for damage caused by failure to observe the above information. The warranty expires in the event that work is carried out by agents we have not authorised or if parts are used other than original spare parts.

Claims under the warranty may be made in all countries where this device is sold by authorised dealers. In the event of any claim under the warranty, please return the device to us. The buyer shall bear the costs of transportation and the risk while the device is in transit. The execution of work under the warranty does not affect the warranty period in any way.

The above information does not extend the conditions of warranty and liability contained in the Terms and Conditions of Sale and Delivery of Euro-Gas Management Services Limited.

Any sensor can potentially fail to meet specification without warning. Euro-Gas makes every effort to ensure reliability of all sensors but where life safety is a performance requirement of the product and, where practical, Euro-Gas recommends that all gas sensors and instruments using sensors are checked for response to gas before use.

The data contained in this document is believed to be accurate and reliable. The data given is for guidance only. Euro-Gas Management Services Ltd accepts no liability for any consequential losses, injury or damage resulting from the use of this datasheet or the information contained in it. Customers should test the sensors under their own conditions to ensure that the sensors are suitable for their own requirements and in accordance with the plans and circumstances of the specific project and any standards/regulations pertaining to the country in which the sensors will be utilised. Performance characteristics on this data sheet outline the performance of newly supplied sensors. Any stated warranty term is null and void if the products are used under conditions other than those specified in the corresponding technical datasheet. Output signal can drift below the lower limit over time. This datasheet is not intended to form the basis of a contract and in the interest of product improvement, Euro-Gas reserves the right to alter design features and specifications without notice.

03/20

