

Product Data Sheet

Product Datasheet

A5F+ Carbon Monoxide

Document Purpose

The purpose of this document is to present the performance specification of the A5F+ carbon monoxide sensor.

This document should be used in conjunction with the A5F+ Characterisation Note, Operating Principles OP20 and the Product Safety Datasheet PSDS 16.

The data provided in this document are valid at 20°C, 50% RH and 1013 mBar for 3 months from the date of sensor manufacture. For guidance on sensor performance outside of these limits, please refer to the A5F+ Characterisation Note.

Output signal can drift below the lower limit over time. For guidance on the safe use of the sensor, please refer to Operating Principles OP08.

Product Data Sheet

Technical Specifications

MEASUREMENT

Operating Principle	4-electrode electrochemical
Nominal Range	0 to 10,000 ppm CO
Maximum Overload	20,000 ppm CO
Filter	To remove acid gases
Filter Capacity	> 275,000 ppm hours (900 ppm NO @ 200 ml/min)
Auxiliary Electrode	To compensate for maximum 2000 ppm H ₂ cross interference
Sensitivity*	60 ± 20 nA/ppm
Response Time (T90)*	< 30 seconds
Typical Net Range Baseline*	-2 to +17 ppm CO equivalent (clean air)
Typical Net Baseline Shift	5 ppm CO equivalent (+20°C to +40°C)
Repeatability	< 1% of signal
Linearity	Linear

ELECTRICAL

Resolution	Electronics dependent 1 ppm (based on recommended circuitry)
Recommended Load Resistor	10 Ω
Bias Voltage	0 mV or 250 mV

MECHANICAL

Housing Material	ABS
Weight	13 g (nominal)
Orientation Sensitivity	None

ENVIRONMENTAL

Operating Temperature Range	-20°C to +50°C
Storage Temperature	0°C to +20°C
Operating Pressure Range	Atmospheric ± 10%
Pressure Coefficient	0.010% signal / mbar
Relative Humidity Range	15% to 90% non-condensing

LIFETIME

Long Term Output Drift	< 2% signal loss per month
Expected Operating Life	3 years in air
Storage Life	6 months in original packaging

Product Dimensions

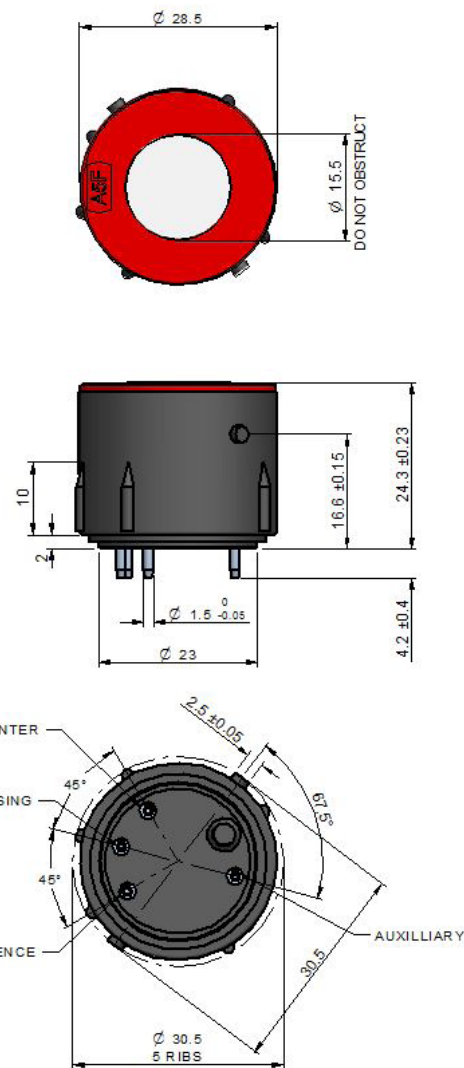

All dimensions in mm

All tolerances ±0.15 mm unless otherwise stated

IMPORTANT NOTE:

Connection should be made via recommended mating parts only. Soldering to the sensor will result in damage and invalidate the warranty.

All performance data is based on conditions at 20°C, 50% RH and 1013 mBar, using recommended circuitry and low rates.

* Specifications are valid at 20°C, 50% RH and 1013 mBar, using recommended circuitry. Performance characteristics outline the performance of sensors supplied within the first 3 months. Output signal can drift below the lower limit over time.

Product Data Sheet

Poisoning

Sensors are designed for operation in a wide range of environments and harsh conditions. However, it is important that exposure to high concentrations of solvent vapours is avoided, both during storage, fitting into instruments, and operation.

When using sensors with printed circuit boards (PCBs), degreasing agents should be used before the sensor is fitted. Do not glue directly on or near the sensor as the solvent may cause crazing of the plastic.

SAFETY NOTE

This sensor is designed to be used in safety critical applications. To ensure that the sensor and/or instrument in which it is used, are operating properly, it is a requirement that the function of the device is confirmed by exposure to target gas (bump check) before each use of the sensor and/or instrument. Failure to carry out such tests may jeopardise the safety of people and property.

Every effort has been made to ensure the accuracy of this document at the time of printing. In accordance with the company's policy of continued product improvement, the manufacturer reserves the right to make product changes without notice. The products are always subject to a programme of improvement and testing which may result in some changes in the characteristics quoted. As the products may be used by the client in circumstances beyond the knowledge and control of the manufacturer, we cannot give any warranty as to the relevance of these particulars to an application. It is the clients' responsibility to carry out the necessary tests to determine the usefulness of the products and to ensure their safety of operation in a particular application.

