

MOX1 MediceL[®] Sensor

MOX1 Oxygen Sensor

Part Number: AA829-210

Document Purpose

The purpose of this document is to present the performance specification of the MOX1 oxygen gas sensor.

This document should be used in conjunction with the Operating Principles (OP04) and the Product Safety Datasheet (PSDS 4).

The data provided in this document are valid at 20°C, 50% RH and 1013 mBar for 3 months from the date of sensor manufacture.

Output signal can drift below the lower limit over time. For guidance on the safe use of the sensor, please refer to the Operating Principles (OP04).



KEY FEATURES & BENEFITS



Meets the requirements
of ISO 80601-2-55



Linear output from
0 % to 100 % O₂



13-month
warranty

RoHS 

RoHS compliant

TECHNICAL SPECIFICATIONS	
MEASUREMENT	
Operating Principle	Partial pressure electrochemical
Output	9 mV to 13 mV in 210 mBar O ₂
Measurement Range	0 mBar to 1500 mBar O ₂
Response Time (T ₉₀)	<15 s (air to 100% O ₂)
Baseline Offset	<200 µV
Linearity	Linear 0% to 100% O ₂ <small>[See Note1]</small>
ELECTRICAL	
Temperature Compensation	<2% O ₂ equivalent (0°C to 40°C)
External Load Resistor	10 kΩ minimum <small>[See Important Note]</small>
Connector	3-pin Molex Header: (Molex 22-29-2031)
Recommended Mating Part	Molex Housing: (Molex 22-01-2035) Molex Crimp Terminals (Molex 08-45-0110)
MECHANICAL	
Housing Material	White ABS
Weight	39 g (nominal)
Orientation	Any
ENVIRONMENTAL	
Typical Applications	Critical care anesthesia
Operating Temperature Range	-20°C to +50°C
Operating Pressure Range	0.5 Bar to 2.0 Bar
Operating Humidity Range	0% to 99% RH non-condensing
LIFETIME	
Long-Term Output Drift in 100% O ₂	< 5% signal loss/year
Recommended Storage Temperature	-10°C to +40°C
Expected Operating Life:	
@ 20°C	1.5 x 10 ⁶ % O ₂ hours
@ 40°C	0.8 x 10 ⁶ % O ₂ hours
Packaging	Sealed blister
Standard Warranty	13 months from date of despatch <small>(This amounts to a variation of condition 6 of our standard terms and conditions which otherwise apply)</small>

Note 1: Use of a regression coefficient shows a best fit straight line better than 0.9995 when measured through the four data points from testing with 100% N₂, 21% O₂, 60% O₂, and 100% O₂.

Product Dimensions mm

N.B. All tolerances ±0.15 mm unless otherwise stated

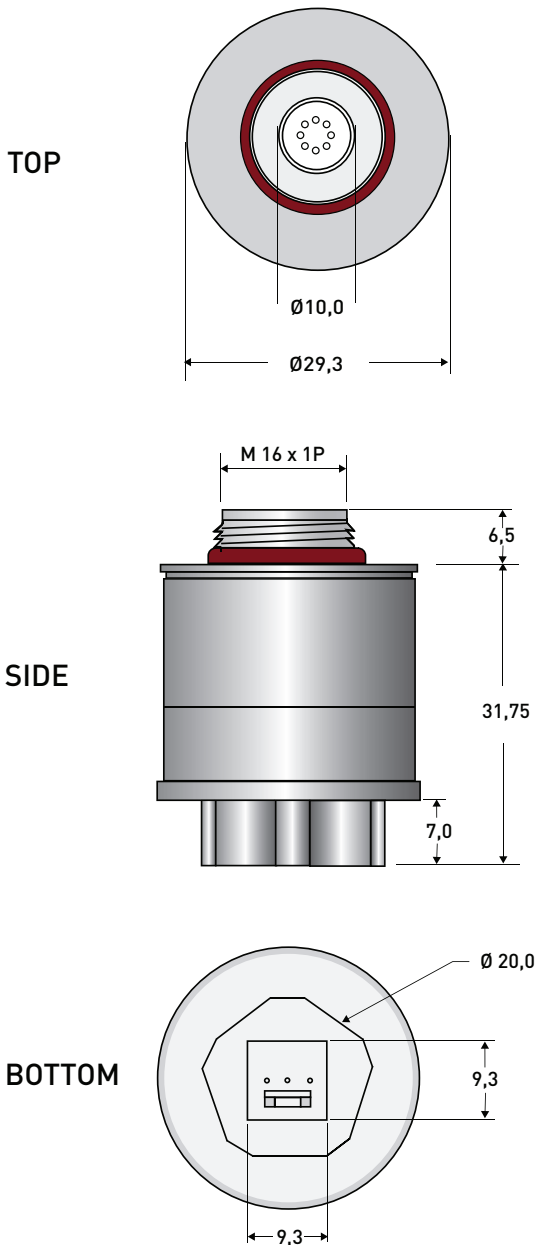

Important Note: Connection should be made via recommended mating parts only. Soldering to the sensor will damage it and invalidate the warranty.

For further information on the external load resistance and connection to the recommended mating part, please see Operating Principle OP-04 or contact us.

All performance data is based on measurements made with cylinder gases using a flow rate of 100 mls/min. Conditions at 20°C, 50% RH and 1013 mBar. For sensor performance data under other conditions, contact us.

Performance characteristics outline the performance of sensors supplied within the first 3 months. Output signal can drift below the lower limit over time.

Poisoning

Sensors are designed for operation in a wide range of environments and harsh conditions. However, it is important that exposure to high concentrations of solvent vapours is avoided, both during storage, fitting into instruments and operation.

When using sensors with printed circuit boards (PCBs), degreasing agents should be used before the sensor is fitted. Do not glue directly on or near the sensor as the solvent may cause crazing of the plastic.

Intended Use

These sensors are designed to be used to monitor the partial pressure of oxygen in anaesthesia (not including xenon), critical care, neonatal incubators, and general oxygen monitors.

Stabilisation Time

Allow at least 15 minutes to stabilise in the instrument before calibration or refer to manufacturers instructions.

Cleaning and Sterilisation

In case of contamination the sensor may be cleaned with distilled water and allowed to dry naturally. The sensor is not suitable for sterilisation by steam or exposure to chemicals such as ethylene oxide or hydrogen peroxide.

Calibration Interval

These sensors are designed to have minimal drift over their useful lifetime. For maximum accuracy however they should be calibrated before each use.

If the Sensor is Dropped

If a sensor is dropped, then it should be placed in quarantine for 24 hours and a follow-up check made by a 2 point calibration.

Mechanical Installation

When installing the sensor, it must only be screwed in hand-tight and a gas tight seal ensured. Spanners and similar mechanical aids may not be used, as excessive force may damage the sensor thread.

RFI/EMI Susceptibility

MediceLs contain metal and may be susceptible to RFI or EMI. They are not suitable for use in MRI environments. For further information please contact us.

Certifications



Cross Sensitivity

The table below shows how MOX1 MediceLs respond when tested with the gas mixtures listed in ISO 80601-2-55.

Test Gas	% O ₂ Error
50% He / 50% O ₂	< 1%
60% N ₂ O / 40% O ₂	< 1%
2% Halothane / 40% O ₂ / 30% N ₂ O / 5% CO ₂ / Bal N ₂	< 1.5%
2% Enflurane / 40% O ₂ / 30% N ₂ O / 5% CO ₂ / Bal N ₂	< 1.5%
2% Isoflurane / 40% O ₂ / 30% N ₂ O / 5% CO ₂ / Bal N ₂	< 1.5%

MOX Adaptor (15 mm Taper)

MOX1 sensors are supplied with an adaptor that can be fitted to the sensor thread and used to direct gas flow to the sensor.

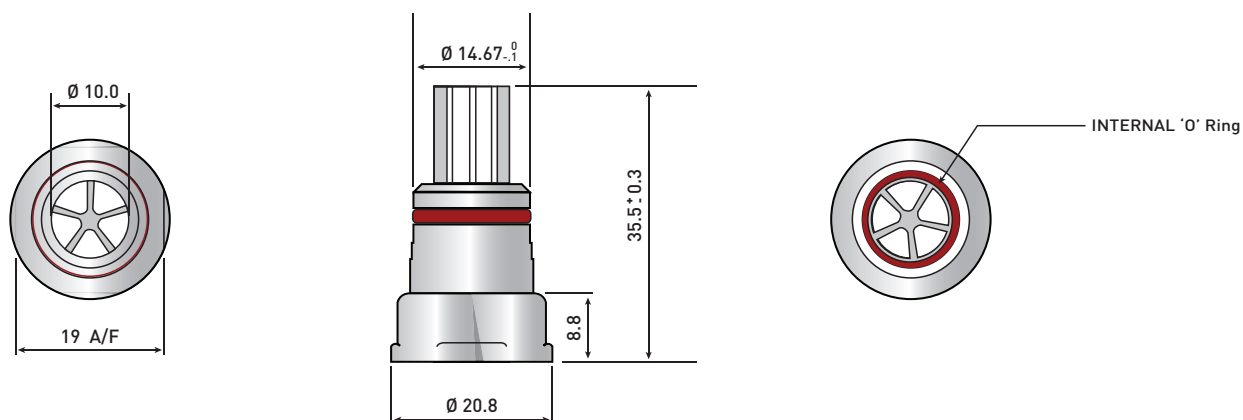

SAFETY NOTE

This sensor is designed to be used in safety-critical applications. To ensure that the sensor and/or instrument in which it is used, are operating properly, it is a requirement that the function of the device is confirmed by exposure to target gas (bump check) before each use of the sensor and/or instrument. Failure to carry out such tests may jeopardize the safety of people and property.

Every effort has been made to ensure the accuracy of this document at the time of printing. In accordance with the company's policy of continued product improvement, the manufacturer reserves the right to make product changes without notice. The products are always subject to a programme of improvement and testing which may result in some changes in the characteristics quoted. As the products may be used by the client in circumstances beyond the knowledge and control of the manufacturer, we cannot give any warranty as to the relevance of these particulars to an application. The manufacturer warrants goods of its manufacture as being free of defective materials and faulty workmanship. The manufacturer's standard product warranty applies unless agreed to otherwise by the manufacturer in writing; please refer to your order acknowledgment or consult your local sales office for specific warranty details. If warranted goods are returned to the manufacturer during the period of coverage, the manufacturer will repair or replace, at its option, without charge those items it finds defective. The foregoing is buyer's sole remedy and is in lieu of all other warranties, expressed or implied, including those of merchantability and fitness for a particular purpose. In no event shall the manufacturer be liable for consequential, special, or indirect damages. Though the manufacturer provides application assistance personally, or through our literature and website, it is up to the customer to determine the suitability of the product in the application.