

Product Data Sheet

Key Features & Benefits:

- ATEX, UL and CSA Approvals
- Withstands EN/IEC 60079-0 impact test
- Enhanced H₂S and silicone poison resistance
- Reduced Orientation Effects

Performance Characteristics

MEASUREMENT

Operating Principle	Catalytic Oxidation
Gases Detected	Combustible gases
Suitable for	Methane, ethane, propane, butane, pentane, hexane, carbon monoxide & hydrogen
Unsuitable for	Higher hydrocarbons, alcohols, ketones, esters, hydrogen sulfide and other sulfur containing compounds
Range	0-100% LEL
Sensitivity*	31 ± 5 mV/%methane
T90 Response Time*	<5 seconds (methane)
Poison Resistance	Resistance to H ₂ S poisoning Superior silicone resistance
H₂S Filter Lifetime	Typically 1000 ppm hr
Linearity	Linear up to 3% methane

ELECTRICAL

Operating Voltage	3.30 ± 0.02 VDC
Detector Operating Current	78 ± 6 mA
Maximum Power Consumption	295 mW
Resolution	1% LEL

MECHANICAL

Weight	2 g (nominal)
Orientation Sensitivity	None

ENVIRONMENTAL

Operating Temperature Range	-20°C to +55°C
Operating Pressure Range	1 atm ± 20%
Operating Humidity Range	0-90% RH non-condensing

LIFETIME

Long Term Span Drift*	<5% signal/month
Long Term Zero Drift*	<5% LEL _{methane} /month
Recommended Storage Temp	0°C to 20°C
Shelf life	6 months in sealed container
Warranty	12 months from date of despatch

Product Dimensions

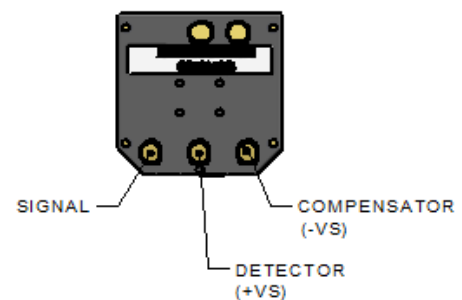
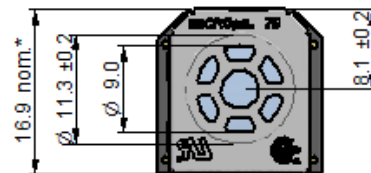

All dimensions in mm

All tolerances ±0.15 mm unless otherwise stated

Note: Fits recommended connector (B700)
Details are available on request

* Specifications are valid at 20°C, 50%RH and 1013 mbar at a flow rate of 300 ml/min. Performance characteristics outline the performance of sensors supplied within the first 3 months. Output signal can drift below the lower limit over time.

Product Data Sheet

Relative Sensitivity

IMPORTANT NOTE

The relative response data shown below does not form part of the product specification and is supplied for guidance only. For the most accurate measurements, an instrument should be calibrated using the gas under investigation.

The table below shows the variation in response of the MICROpeL on exposure to a range of gases and vapours at the same %LEL concentration. The figures are experimentally derived and expressed relative to the methane signal (=100). Testing was performed using 2.5%vol. CH₄ (50%LEL CH₄ based on LEL values from the now obsolete EN50054).

Relative response data are shown in the table below, based on the LEL values stated in EN 50054 (now obsolete) and EN60079-20-1:2010.

Gas / Vapour	Relative Sensitivity **	
	EN 50054 (obsolete)	EN 60079-20-1:2010
Methane	100	100
Propane	61	56
n-Butane	68	58
n-Pentane	63	72
Hydrogen	127	144
Ethylene	101	96
Acetylene	96	99
n-Heptane	49	61
** Each sensitivity has been rounded to the nearest 1%		

Product Approvals

Approval Body: **SIRA CERTIFICATION SERVICE**

Test Standard:
 EN 60079-0:2012 Explosive Atmospheres Part 0 - General Requirements
EN 60079-1:2014 Explosive Atmospheres - Equipment Protection by Flameproof Enclosures "d"
EN 60079-11:20012 Explosive Atmospheres - Equipment Protection by Intrinsic Safety "i"
EN 60079-31:20014 Explosive Atmospheres - Equipment Dust Ignition Protection by Enclosure "t"

Certification Code: Refer to section 7.2

Certification Number: Sira 02ATEX1161X

Atex Marking:  II2 GD/IM2  0518

Product Data Sheet

Instructions specific to hazardous area installations (reference European ATEX Directive 94 / 9 / EC, Annex II, 1.0.6.)

The following instructions apply to equipment covered by certificate number Sira 02ATEX1161X;

1. The equipment may be used with flammable gases and vapours with apparatus groups IIA, IIB and IIC and with temperature classifications T1, T2, T3 and T4.
2. The equipment is certified for use in ambient temperatures of -20°C to +55°C.
3. The equipment has not been assessed as a safety related device (as referred to by Directive 94 / 9 / EC Annex II, clause 1.5).
4. Installation of the equipment shall be carried out by suitably trained personnel in accordance with the applicable code of practice (e.g. EN 60079-14)
5. Inspection and maintenance of this equipment shall be carried out by suitably trained personnel in accordance with the applicable code of practice (e.g. EN 60079-17).
6. Repair of this equipment shall be carried out by suitably trained personnel in accordance with the applicable code of practice (e.g. EN 60079-19).
7. The 'X' suffix to the certificate number relates to the following conditions for safe use;
 - 7.1 The product does not meet the drop tests described in EN 60079-0:2012 clauses 26.4.2 and 26.4.3. It shall therefore be protected from mechanical stresses caused by impact.
 - 7.2 The Micropel models have the following power and temperature ranges:

Micropel 75 models	Ex db ia I Mb (Ta -20°C to +55°C) @ Pmax 0.8W
	Ex da ia IIC T4 Ga (Ta -20°C to +55°C) @ Pmax 0.8W
	Ex t IIIC T135°C IP6X Db (Ta -20°C to +55°C) @ Pmax 0.8W
or	
	Ex db ia I Mb (Ta -20°C to +40°C) @ Pmax 0.49W
	Ex da ia IIC T5 Ga (Ta -20°C to +40°C) @ Pmax 0.49W
	Ex t IIIC T100°C IP6X Db (Ta -20°C to +40°C) @ Pmax 0.49W
or	
	Ex db ia I Mb (Ta -20°C to +55°C) @ Pmax 0.42W
	Ex da ia IIC T5 Ga (Ta -20°C to +55°C) @ Pmax 0.42W
	Ex t IIIC T100°C IP6X Db (Ta -20°C to +55°C) @ Pmax 0.42W
- 7.3 The Micropel miniature combustible gas sensors shall only be connected to a gas detector that provides a maximum, output power (P_0) not greater than that detailed in the list above. In the case of the Micropel 75 models, this shall be an intrinsically safe supply.
- 7.4 This product is not resistant to light as required by clause 7.3 of EN60079-0:2012. Therefore, it shall only be installed in a location where it is not exposed to direct sunlight or any other source of ultraviolet (UV) light.
- 7.5 This sensor is not a standalone device. It is the responsibility of the detector / instrument manufacturer or designer that uses the sensor to ensure that the sensors are connected to ground with a maximum impedance of $10^9 \Omega$.

Product Data Sheet

8. It is recommended that confirmation of adequate sensor performance be conducted on a regular basis by means of a defined, sensor calibration procedure. The calibration frequency will depend upon the environment in which the sensor is operated and on the perceived level of risk from the build up of flammable atmospheres.

9 The certification of this equipment relies upon the following materials used in its construction:

Enclosure Material: PEI, PPS or PTFE

Flame arrester: Stainless steel 316 mesh

If the equipment is likely to come into contact with aggressive substances, then it is the responsibility of the user to take suitable precautions that prevent it from being adversely affected, thus ensuring that the type of protection is not compromised.

Aggressive substances: e.g. acidic liquids or gases that may attack metals, or solvents that may affect polymeric materials.

Suitable precautions: regular checks as part of routine inspections or establishing from the material's data sheet that it is resistant to specific chemicals.

10. The MICROpeL™ is available in several formats. Each will carry the certification shown in 10.1 on the sensor and as shown in 10.2 on the packaging:

10.1

MODEL DESIGNATION

SERIAL NUMBER (to include year of manufacture)

Sira 02ATEX1161X



I M2
II 1G
II 2D

The sensor may also contain information relevant to other certification bodies

10.2

MODEL DESIGNATION

Ex db ia I Mb; Ex da ia IIC T4 Ga; Ex t IIIC T135°C IP6X Db
(Ta -20°C to +55°C) @ Pmax 0.8W

The packaging may also contain information relevant to other certification bodies, as well as information e.g. patent numbers, of a non-certification nature.



Product Data Sheet

11. Certain substances are known to have a detrimental effect on catalytic elements as used in the MICROpeL™ series.

Poisoning: some compounds will decompose on the catalyst and form a solid barrier over the catalyst surface. This action is cumulative and prolonged exposure will result in an irreversible decrease in sensitivity. The most common of these substances are: lead or sulphur containing compounds; silicones; phosphates.

Inhibition: certain other compounds, especially hydrogen sulphide and halogenated hydrocarbons, are absorbed or form compounds that are absorbed by the catalyst. The resultant loss of sensitivity is temporary and in most cases a sensor will recover after a period of operation in clean air.

In applications where it is suspected that poisons or inhibitors may be present, suitable protection for the MICROpeL™ should be provided.

Approval Body: UNDERWRITERS LABORATORIES INC.

Test Standard: UL913



Product Categories: Class I, Division 1, Groups A,B,C and D.

File Number: E180262

Conditions of Acceptability

1. These devices shall be installed in a suitable enclosure in accordance with the end product standard.
2. These devices shall be used within their specified electrical ratings.
3. These devices are intended for use in intrinsically safe circuits or within intrinsically safe devices.
4. Temperature test is to be performed on end use product.

Approval Body: CANADIAN STANDARDS ASSOCIATION

Test Standards: CAN/CSA E60079-0:02, Part 0
CAN/CSA E60079-1:02, Part 1
CAN/CSA E60079-11:02, Part 11
CAN/CSA - C22.2.No 157-92



Product Categories: Class I, Division 1, Groups A, B, C, D and T3C

File Number: 103143

Product Data Sheet

Notes

1. The sensor (operating voltage 3.3V) is suitable as intrinsically safe for Class I, Division 1, Groups A, B, C, D, T3C when connected in compatible intrinsically safe gas detector circuits under assessed fault conditions.
2. Certified as a component where the combustible gas performance tests shall be conducted on the gas detector, and final assembly subject to acceptance by CSA. The final assembly of the gas detector shall determine the markings or suitability in the appropriate hazardous location.
3. The sensor shall be protected from mechanical stresses caused by impact and drop tests. The applicable tests shall be conducted in the final assembly.

SAFETY NOTE

This sensor is designed to be used in safety critical applications. To ensure that the sensor and/or instrument in which it is used, are operating properly, it is a requirement that the function of the device is confirmed by exposure to target gas (bump check) before each use of the sensor and/or instrument. Failure to carry out such tests may jeopardize the safety of people and property.

Every effort has been made to ensure the accuracy of this document at the time of printing. In accordance with the company's policy of continued product improvement, the manufacturer reserves the right to make product changes without notice. No liability is accepted for any consequential losses, injury or damage resulting from the use of this document or from any omissions or errors herein. The data is given for guidance only. It does not constitute a specification or an offer for sale. The products are always subject to a programme of improvement and testing which may result in some changes in the characteristics quoted. As the products may be used by the client in circumstances beyond the knowledge and control of the manufacturer, we cannot give any warranty as to the relevance of these particulars to an application. It is the clients' responsibility to carry out the necessary tests to determine the usefulness of the products and to ensure their safety of operation in a particular application.

