

Product Data Sheet

Product Datasheet 3CLH Chlorine Sensor

Document Purpose

The purpose of this document is to present the performance specification of the 3CLH Chlorine gas sensor.

This document should be used in conjunction with the Operating Principles (OP08) and the Product Safety Datasheet (PSDS 5).

The data provided in this document are valid at 20°C, 50% RH and 1013 mBar for 3 months from the date of sensor manufacture.

Output signal can drift below the lower limit over time. For guidance on the safe use of the sensor, please refer to the Operating Principles OP08.

Product Data Sheet

- Key Features & Benefits:**
- Robust, 3-Series packaging
 - Range of accessories available

Technical Specifications

MEASUREMENT

Operating Principle	3-electrode electrochemical
Measurement Range	0-20 ppm Cl ₂
Maximum Overload	250 ppm Cl ₂
Filter	None
Sensitivity*	1.00 ± 0.25 µA/ppm
Resolution	0.1 ppm
Response Time (T₈₀)*	< 60 s
Baseline Offset (clean air)	0 to +0.5 ppm equivalent
Zero Shift (+20°C to +40°C)	-0.2 ppm equivalent
Repeatability	2% of signal
Linearity	Linear

ELECTRICAL

Recommended Load Resistor	33 Ω
Bias Voltage	Not required

MECHANICAL

Weight	22 g
Orientation	Any

ENVIRONMENTAL

Operating Temperature Range	-20°C to +50°C
Recommended Storage Temp	0°C to 20°C
Operating Pressure Range	Atmospheric ± 10%
Operating Humidity Range	15 - 90% RH non-condensing

LIFETIME

Long Term Sensitivity Drift*	<2% signal loss/month
Expected Operating Life	Two years in air
Storage Life	6 months in original container

Product Dimensions

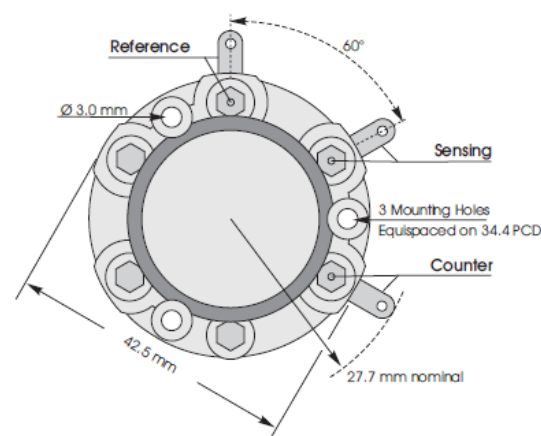
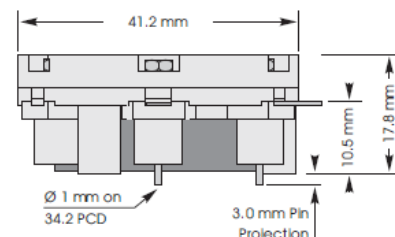

All dimensions in mm
All tolerances ±0.15 mm unless otherwise stated
3CLH shown with side tags and gold pins

AVAILABLE OPTIONS

Sensor	Description	Part Number
3CLH	With side tag and PCB pin connections	AH002-J00
3CLH(G)	With gold-plated PCB pin connection	AH002-300

IMPORTANT NOTE:

Soldering to the pin connections will seriously damage the sensor and invalidate the warranty.

* Specifications are valid at 20°C, 50% RH and 1013 mBar, using recommended circuitry. Performance characteristics outline the performance of sensors supplied within the first 3 months. Output signal can drift below the lower limit over time.

Product Data Sheet

Poisoning

Sensors are designed for operation in a wide range of environments and harsh conditions. However, it is important that exposure to high concentrations of solvent vapours is avoided, both during storage, fitting into instruments and operation.

When using sensors with printed circuit boards (PCBs), degreasing agents should be used before the sensor is fitted. Do not glue directly on or near the sensor as the solvent may cause crazing of the plastic.

Cross Sensitivity Table

Whilst sensors are designed to be highly specific to the gas they are intended to measure, they will still respond to some degree to various other gases. The table below is not exclusive and other gases not included in the table may still cause a sensor to react.

IMPORTANT NOTE : The cross sensitivity data shown below does not form part of the product specification and is supplied for guidance only. Values quoted are based on tests conducted on a small number of sensors and any batch may show significant variation. For the most accurate measurements, an instrument should be calibrated using the gas under investigation.

Gas	Concentration Used (ppm)	3CLH (ppm Cl ₂)
Carbon Monoxide, CO	300	0
Hydrogen Sulfide, H ₂ S	15	~ -1.5
Sulfur Dioxide, SO ₂	10	-0.1 < x\$ < 0
Nitric Oxide, NO	35	0
Nitrogen Dioxide, NO ₂	5	~ 5
Hydrogen, H ₂	100	0
Hydrogen Cyanide, HCN	10	0
Hydrogen Chloride, HCl	5	0
Ethylene, C ₂ H ₄	100	0

SAFETY NOTE

This sensor is designed to be used in safety critical applications. To ensure that the sensor and/or instrument in which it is used, are operating properly, it is a requirement that the function of the device is confirmed by exposure to target gas (bump check) before each use of the sensor and/or instrument. Failure to carry out such tests may jeopardise the safety of people and property.

Every effort has been made to ensure the accuracy of this document at the time of printing. In accordance with the company's policy of continued product improvement, the manufacturer reserves the right to make product changes without notice. The products are always subject to a programme of improvement and testing which may result in some changes in the characteristics quoted. As the products may be used by the client in circumstances beyond the knowledge and control of the manufacturer, we cannot give any warranty as to the relevance of these particulars to an application. It is the clients' responsibility to carry out the necessary tests to determine the usefulness of the products and to ensure their safety of operation in a particular application.