

Product Data Sheet

Product Datasheet 4COSH Dual Gas CO / H₂S Sensor

Document Purpose

The purpose of this document is to present the performance specification of the 4COSH dual gas sensor.

This document should be used in conjunction with Operating Principles OP20 and the Product Safety Datasheet (PSDS 5).

The data provided in this document are valid at 20°C, 50% RH and 1013 mBar for 3 months from the date of sensor manufacture.

Output signal can drift below the lower limit over time. For guidance on the safe use of the sensor, please refer to Operating Principles OP20.

Product Data Sheet

- Key Features & Benefits**
- Robust, industry standard 4-Series packaging
 - Compact Size

Technical Specification

MEASUREMENT

Operating Principle	3-electrode electrochemical
Measurement Range	CO : 0-500 ppm H ₂ S : 0-200 ppm
Maximum Overload	CO : 1500 ppm H ₂ S : 500 ppm
Filter	To remove H ₂ S from CO channel
Sensitivity*	CO : 80 ± 30 nA/ppm H ₂ S : 775 ± 275 nA/ppm
Response Time (T₉₀)*	CO : <35 Seconds at 20°C H ₂ S : <35 Seconds at 20°C
Typical Baseline Range	CO : -2 to +3 ppm equiv. H ₂ S : -0.4 to +0.4 ppm equiv.
Resolution	CO : 1.0 ppm H ₂ S : 0.5 ppm
Repeatability	CO : < 3% of signal H ₂ S : < 2% of signal
Linearity	Linear

When using recommended electronics

ELECTRICAL

Recommended Load Resistor	10 Ω
Bias Voltage	Not required

MECHANICAL

Weight	5 g approx.
Housing Material	ABS
Orientation	Any

ENVIRONMENTAL

Operating Temperature Range	-20°C to +50°C
Recommended Storage Temp	0°C to 20°C
Operating Pressure Range	Atmospheric ± 10%
Operating Humidity Range	15 - 90% RH non-condensing

LIFETIME

Long Term Sensitivity Drift	<30% signal loss/operating life
Expected Operating Life	3 years in air
Storage Life	6 months in original container

Product Dimensions

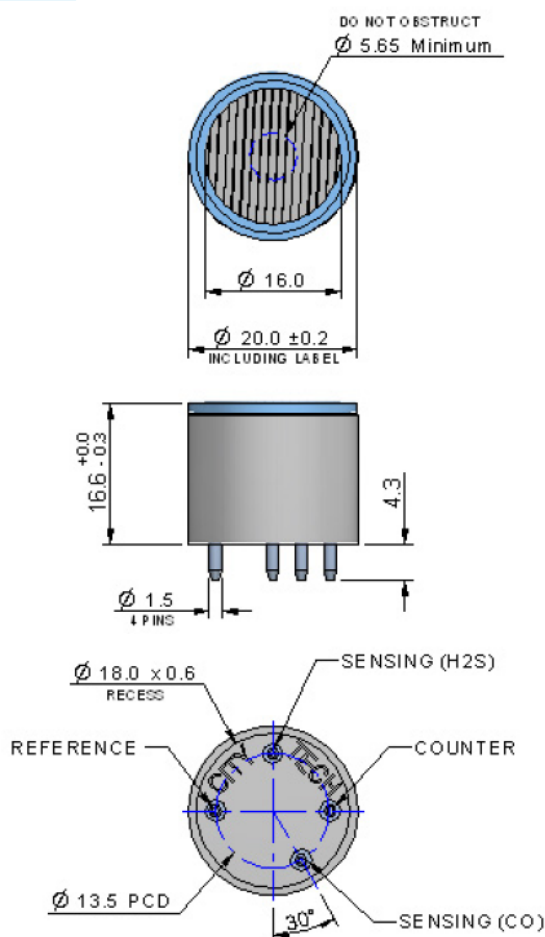

All dimensions in mm
All tolerances ±0.15 mm unless otherwise stated

IMPORTANT NOTE: Connection should be made via PCB sockets only. Soldering to the pins will seriously damage your sensor and invalidate the warranty.

* Specifications are valid at 20°C, 50% RH and 1013 mBar, using recommended circuitry. Performance characteristics outline the performance of sensors supplied within the first 3 months. Output signal can drift below the lower limit over time.

Product Data Sheet

Poisoning

Sensors are designed for operation in a wide range of environments and harsh conditions. However, it is important that exposure to high concentrations of solvent vapours is avoided, both during storage, fitting into instruments and operation.

When using sensors with printed circuit boards (PCBs), degreasing agents should be used before the sensor is fitted. Do not glue directly on or near the sensor as the solvent may cause crazing of the plastic.

Cross Sensitivity Table

Whilst sensors are designed to be highly specific to the gas they are intended to measure, they will still respond to some degree to various other gases. The table below is not exclusive and other gases not included in the table may still cause a sensor to react.

IMPORTANT NOTE : The cross sensitivity data shown below does not form part of the product specification and is supplied for guidance only. Values quoted are based on tests conducted on a small number of sensors and any batch may show significant variation. For the most accurate measurements, an instrument should be calibrated using the gas under investigation.

Gas	Concentration Used (ppm)	ppm on H ₂ S channel	ppm on CO channel
Carbon Monoxide, CO	300	< 6	300
Hydrogen Sulfide, H ₂ S	15	16	<6
Hydrogen, H ₂	100	0.03	~ 20
Nitric Oxide, NO	35	< 1	< 0.1
Nitrogen Dioxide, NO ₂	5	~ -1	< 0.1
Chlorine, Cl ₂	1	0	0
Sulfur Dioxide, SO ₂	5	< 1	0

SAFETY NOTE

This sensor is designed to be used in safety critical applications. To ensure that the sensor and/or instrument in which it is used, are operating properly, it is a requirement that the function of the device is confirmed by exposure to target gas (bump check) before each use of the sensor and/or instrument. Failure to carry out such tests may jeopardise the safety of people and property.

Every effort has been made to ensure the accuracy of this document at the time of printing. In accordance with the company's policy of continued product improvement, the manufacturer reserves the right to make product changes without notice. The products are always subject to a programme of improvement and testing which may result in some changes in the characteristics quoted. As the products may be used by the client in circumstances beyond the knowledge and control of the manufacturer, we cannot give any warranty as to the relevance of these particulars to an application. It is the clients' responsibility to carry out the necessary tests to determine the usefulness of the products and to ensure their safety of operation in a particular application.