

ECO-Sure X SENSOR

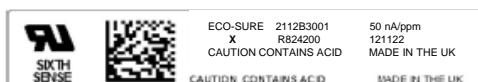

LABEL DETAILS



Specifications are more ideal for when the sensor is used at 20°C, 50% RH and 1013mBar, using recommended circuitry. Performance characteristics outline the performance of sensors supplied within the first three months. With the exception of items marked * the stated parameters have been verified under the UL component recognition programme.

Note: PCB sockets are recommended for the sensor pin connection. Soldering or using glue with the sensor should be avoided and will invalidate warranty.

The ECO-Sure® 'X' is a long life, high quality, cost effective 2-electrode electromechanical cell designed for the detection of Carbon Monoxide CO in a range of applications but particularly for domestic/residential Carbon Monoxide detection, industrial fire detection and ventilation control. The 'X' version offers a 10 year warranted lifetime. This sensor is renowned worldwide for its long lifetime and stable performance. The ECO-Sure X is a recognised component under UL2075.

TECHNICAL SPECIFICATIONS

Operating Principle:	2-electrode electrochemical
Gas Detected:	Carbon Monoxide CO
Measurement Range:	0 – 500 ppm
Maximum Overload:	1,000 ppm
Expected Operating Life*:	> 10 years in normal use from date of manufacture
Sensitivity:	50 ± 10 nA per ppm
Operating Temperature Range*:	Continuous: -10°C to +50°C Intermittent: -20°C to +50°C
Pressure Range:	1 atm ± 10%
Operating Humidity Range* (non-condensing):	Continuous: 15 - 90% Intermittent: 0 - 99%
Response Time (T90):	< 30 seconds
Baseline Offset (clean air):	-2 to 4 ppm equivalent
Zero Shift* (-10°C to +50°C):	< +10 ppm equivalent
Long Term Output Drift:	< 5% signal drift per annum
Repeatability:	< ± 5%
Linearity:	Within ± 5%
Recommended Load Resistor:	5 Ω
Bias Voltage:	Not required

Intrinsic Safety Data*

Maximum at 1,000ppm:	0.1mA
Maximum o/c Voltage:	1.3V
Maximum s/c Current:	< 1.0A



ECO-Sure X SENSOR



Physical Specifications

- Weight:** 5g (nominal)
Orientation: Any
Housing Material: Noryl N110
Storage Life: 6 months in original sealed container
Storage Conditions: +10°C to +30°C
Warranty Period: 10 years from date of manufacture
Part Number: 2112B3001
Diameter of pins: 1.55mm
Recommended sockets: available from Euro-Gas.

Note: PCB sockets are recommended for the sensor pin connection. Soldering or using glue with the sensor should be avoided and will invalidate warranty.

Specifications are more ideal for when the sensor is used at 20°C, 50% RH and 1013mBar, using recommended circuitry. Performance characteristics outline the performance of sensors supplied within the first three months. With the exception of items marked * the stated parameters have been verified under the UL component recognition programme.

DATA MATRIX SPECIFICATION

LABEL DETAILS

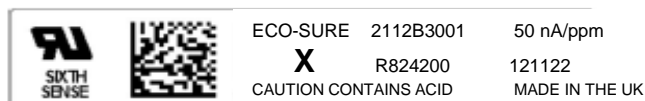

DATAMATRIX CODE AT APPROX 4,5° OFFSET FROM CENTRELINE OF "C" PIN (TOWARDS "W" PIN)

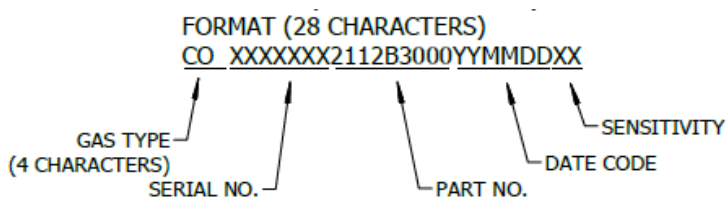

DataMatrix Format: 28 CHARACTERS

Data contained in Data Matrix code: 28 character encrypted number with gas type, sensor serial number, part number, date code (YYMMDD) and sensitivity in nA/ppm.

Scanning recommendations: In order to achieve a reliable read rate, the installation of a fixed scanning device is recommended, such as a fixed scanner from www.datalogic.com. The scanner should be set to dot matrix. A white ring light should be positioned above the cell to be scanned in preference to the scanners in-built light source. A hand held scanner can be used but a reduction in read rate may be experienced.

Encryption and software licence: Data contained in the Data Matrix code is encrypted. Encryption software and user licence are required to convert the data.



EURO-GAS MANAGEMENT SERVICES LTD, CHURSTON HOUSE, BASCOMBE ROAD, CHURSTON FERRERS, DEVON, TQ5 0JJ, UK

☎: +44 (0)1803 844414 Fax: +44 (0)1803 844224
sales@euro-gasman.com www.euro-gasman.com

EURO-GAS
MANAGEMENT SERVICES LTD

ECO-Sure X SENSOR

MANUFACTURING & OUTPUT PERFORMANCE

ECO-Sure X sensors are manufactured on a fully automated manufacturing line. This process enables the product to be both more repeatable and reproduceable resulting in Six Sigma levels of output performance. Our automated manufacturing line provides superior quality advantages, including tight sensitivity control on every batch of sensors, ensuring repeatable technical parameters for each and every sensor. Batches of 10,000 ECO-Sure sensors can be produced on a daily basis on the automated production line, providing security and speed of supply from our UK manufacturing base.

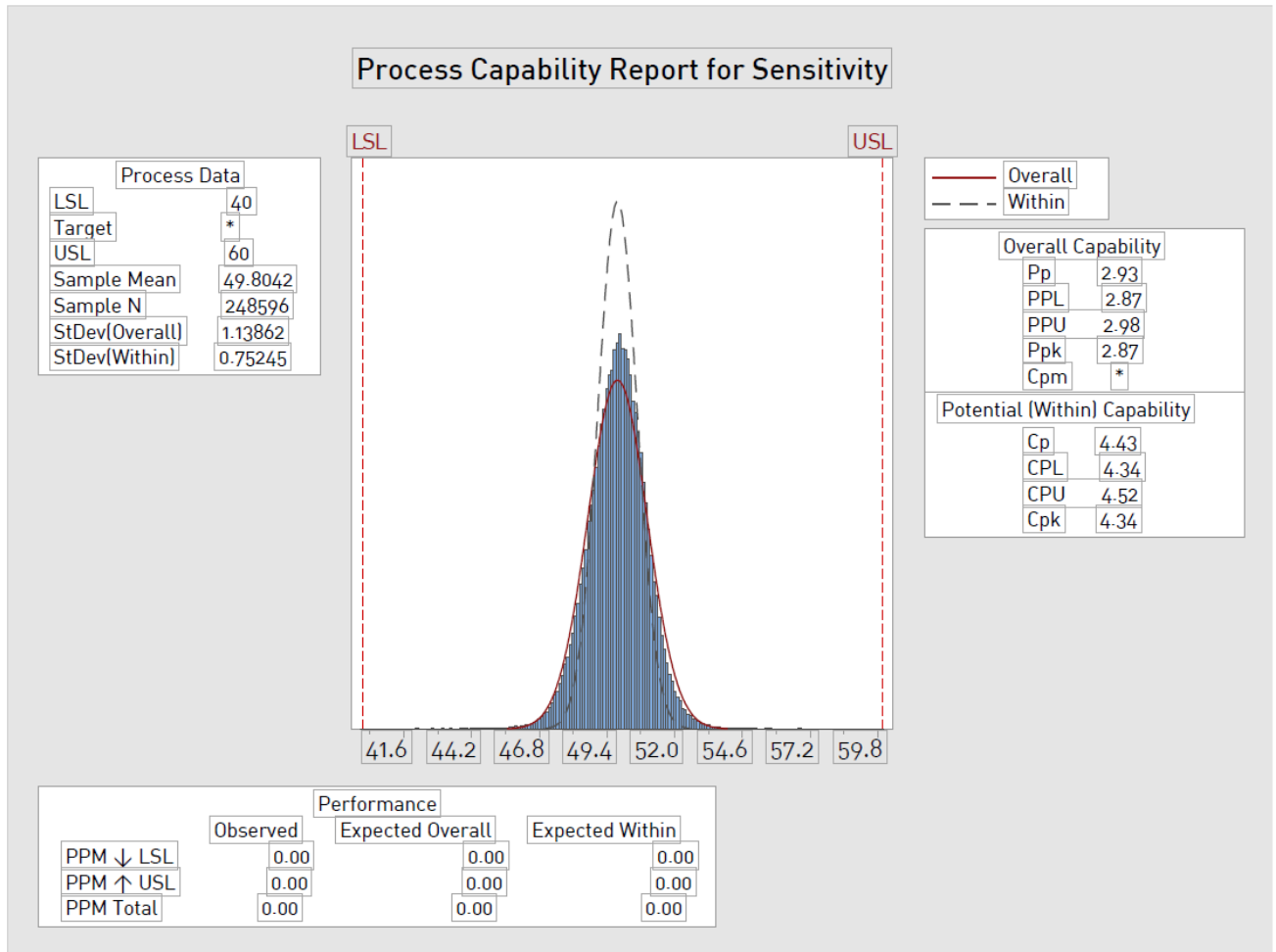

ECO-Sure X SENSOR

Linearity of ECO-Sure Cells (0 to 1250 ppm CO)

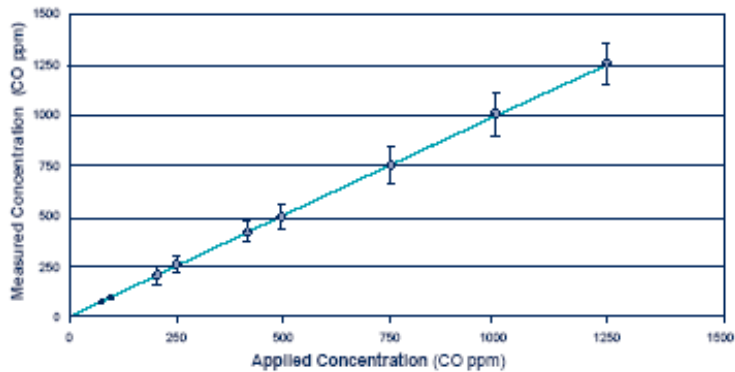

Note: Temperature coefficients and cross-sensitivity are not verified under the UL component recognition programme . Temperature coefficients and cross-sensitivity do not form part of the product specification and are supplied for guidance only.

Temperature Coefficients of ECO-Sure Cells

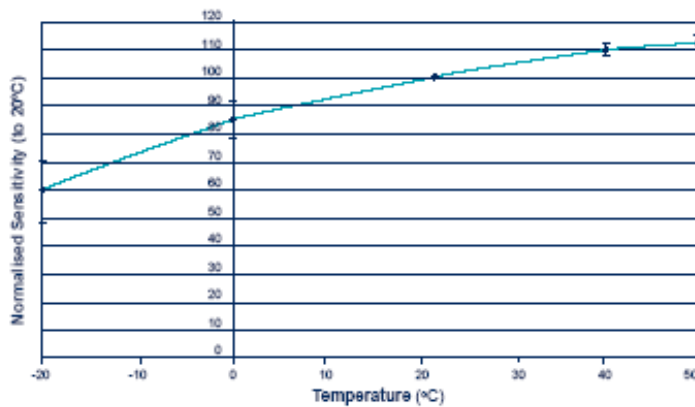

POISONING

Gas sensors are designed for operation in a wide range of environments and harsh conditions. However, it is important that exposure to high concentration of solvent vapours is avoided, during storage, fitting into instruments and in operation.

When using sensors with printed circuit boards (pcbs), degreasing agents should be used before the sensor is fitted. Do not glue directly on or near the sensor, as the solvent may cause crazing of the plastic.



ECO-Sure X SENSOR

CROSS SENSITIVITY

Whilst the ECO-Sure X is designed to be highly specific to the gas it is intended to measure, it will still respond to some degree to various gases. The table below is not exclusive and other gases not included in the table may still cause a sensor to react. The cross-sensitivity data shown below does not form part of the product specification and is supplied for guidance only. For the most accurate measurements, an instrument should be calibrated using the gas under investigation with certified calibration gas.

The cross-sensitivity values quoted are based on tests conducted on a small number of sensors. They are intended to indicate sensor response to gases other than the target gas. Sensors may behave differently with changes in ambient conditions and any batch may show significant variation from the values quoted.

The figures in this table are typical values and should not be used as a basis for cross calibration. Cross sensitivities may not be linear and should not be scaled. For some cross interference, break through will occur if gas is applied for a longer time period.

Gas	Concentration Used (ppm)	Exposure Time (mins)	Reading (ppm CO)
Carbon Monoxide CO	100	5	100
Hydrogen Sulphide H ₂ S	25	5	0
Sulphur Dioxide SO ₂	50	600	<0.5
Nitrogen Dioxide NO ₂	50	900	-1
Nitric Oxide NO	50	5	8
Chlorine Cl ₂	2	5	0
Hydrogen H ₂	100	5	20
Carbon Dioxide CO ₂	5000	5	0
Ammonia NH ₃	100	5	0
Ethanol C ₂ H ₅ OH	2000	30	5
Iso-Propanol	200	120	0
Acetone	1000	5	0
Acetylene	40	5	80

By the nature of the technology used, any sensor can potentially fail to meet specification without warning. Euro-Gas makes every effort to ensure reliability of all sensors but where life safety is a performance requirement of the product and, where practical, Euro-Gas recommends that all gas sensors and instruments using sensors are checked for response to gas before use.

The data contained in this document is believed to be accurate and reliable. The data given is for guidance only. Euro-Gas Management Services Ltd accepts no liability for any consequential losses, injury or damage resulting from the use of this datasheet or the information contained in it. Customers should test the sensors under their own conditions to ensure that the sensors are suitable for their own requirements and in accordance with the plans and circumstances of the specific project and any standards/regulations pertaining to the country in which the sensors will be utilised. Performance characteristics on this data sheet outline the performance of newly supplied sensors. Output signal can drift below the lower limit over time. This datasheet is not intended to form the basis of a contract and in the interest of product improvement, Euro-Gas reserves the right to alter design features and specifications without notice. 07/20



ECO-Sure X SENSOR

OPTIONS & ACCESSORIES

- **ECO-Sure X CO sensor with 4-20mA transmitter** (with TÜV approval according to VDI 2053 systems). Part no: 2112B1005X. Standard measuring range: 0-300ppm. Optional measuring range: 0-500ppm.
- **Installation kit.** Part no: 2112B1022.
- **Test/calibration gas cap.** Part no: 2112B1010.
- **Gas Measuring System.** ECO-Sure X sensor, 4-20mA transmitter and installation kit provided as a complete unit in aluminium housing. Part no: 2112B1013X.



Figure 1.
**ECO-Sure X CO sensor
+ 4-20mA transmitter**
Part no. 2112B1005X
(with TÜV approval
according to VDI 2053
systems)

Figure 2.

Gas Measuring System

ECO-Sure X sensor with 4-20mA transmitter and installation kit, provided as a complete unit, fitted into aluminium housing. Part no. 2112B1013X. Standard measuring range: 0-300ppm CO. Optional measuring range: 0-500ppm CO.

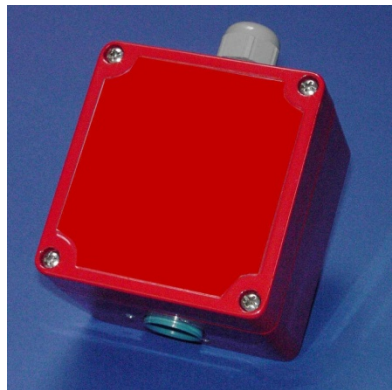

Figure 3.
Test/calibration gas cap
Part no. 2112B1010



ECO-Sure X SENSOR

SENSOR DIMENSIONS

All dimensions in mm. All tolerances ± 0.15 mm unless otherwise stated.

TOP VIEW

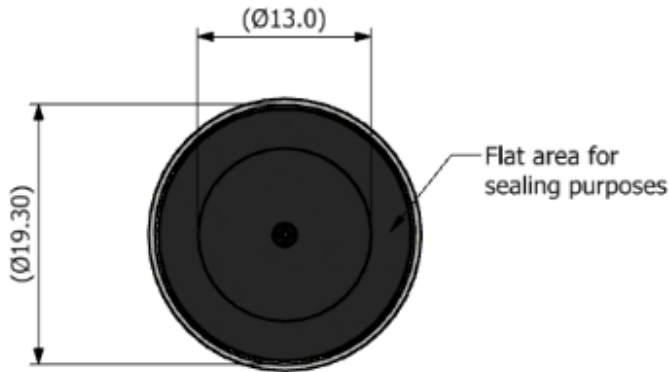

SIDE VIEW

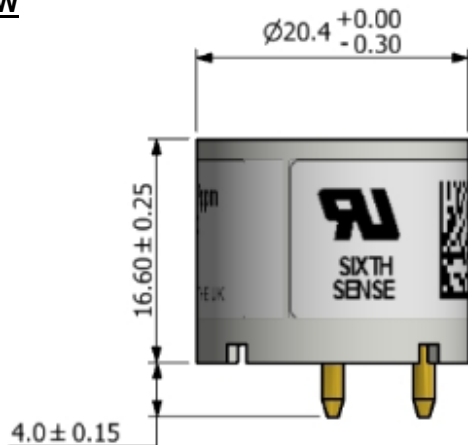

BASE VIEW

