

4-Cl₂-10 CHLORINE SENSOR

0-10PPM Cl₂

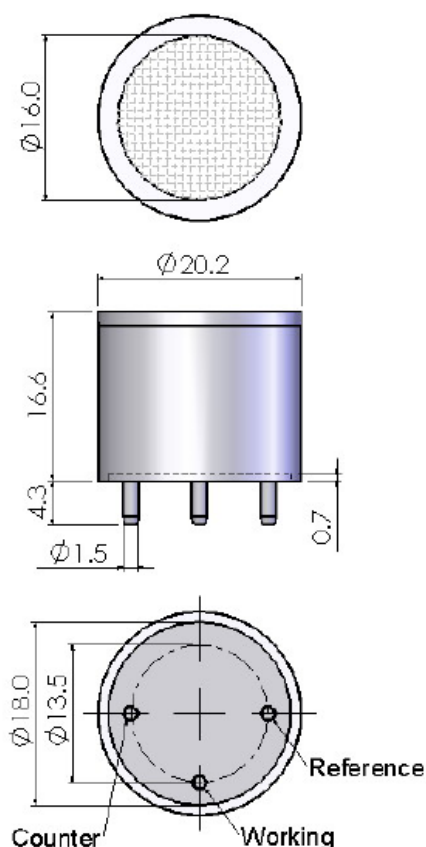

Outline Dimensions



All dimensions are in millimetres mm.

All tolerances are +/- 0.2mm.

Note: PCB sockets are recommended for the sensor pin connection. Soldering to the sensor should be avoided and will invalidate warranty.

All performance specifications are based upon the following environment conditions: +20°C, 50% relative humidity and 1 atm (1013 mBar or ambient pressure).

SPECIFICATION – 4 SERIES

Operating Principle:	Electrochemical, 3-electrode cell
Gas Detected:	Chlorine CL ₂
Measurement Range:	0 – 10 ppm
Maximum Range:	50 ppm
Resolution:	0.1 ppm
Expected Operating Life:	2 years in air
Temperature Range:	-20°C to +50°C
Humidity Range (non-condensing):	15 – 90% RH
Response Time (T90):	≤ 30 seconds
Long Term Sensitivity Drift:	< 2% signal per month
Linearity at Standard Range:	Linear
Sensitivity:	0.75 +/- 0.15 µA/ppm
Baseline (20°C):	< +/- 1.0 µA
Baseline Drift (-20°C to 40°C):	0 to -0.3 ppm equivalent
Pressure range:	Atmospheric +/-10%
Bias Potential:	0 mV
Warranty Period:	12 months from date of despatch
Storage Life:	6 months in original sealed container
Storage Temperature:	0°C to +20°C
Weight (approx):	5 g
Orientation Sensitivity:	None
Part Number:	2112B0911400



**EURO-GAS MANAGEMENT SERVICES LTD, CHURSTON HOUSE,
BASCOMBE ROAD, CHURSTON FERRERS, DEVON, TQ5 0JJ, UK**

☎: +44 (0)1803 844414 Fax: +44 (0)1803 844224

sales@euro-gasman.com www.euro-gasman.com

EURO-GAS
MANAGEMENT SERVICES LTD

4-CI2-10 CHLORINE SENSOR 0-10PPM CI2

CROSS SENSITIVITY DATA

Gas	Concentration (ppm)	Output Signal (ppm Cl ₂ equivalent)
Hydrogen Sulphide	20	-4
Carbon Monoxide	100	0
Sulphur Dioxide	20	0
Nitric Oxide	35	0
Nitrogen Dioxide	10	12
Hydrogen	3000	0
Ammonia	100	0
Carbon Dioxide	10000	0
Chlorine Dioxide	1	3.5

Notes: Calibration with cross-sensitivity gas is not recommended. The cross-sensitivity may fluctuate between +/- 30% and may differ from batch to batch and within the sensor's lifetime. The cross-sensitivities are including but not limited to the above gases. The sensor may also respond to other gases.

TEMPERATURE DEPENDENCE

Output vs Temperature

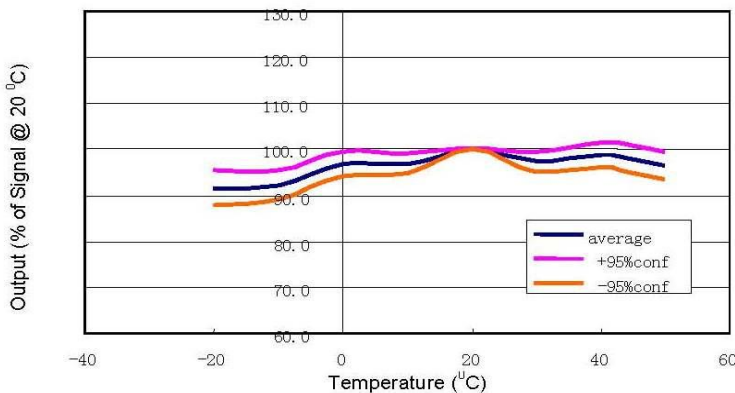

Baseline vs Temperature

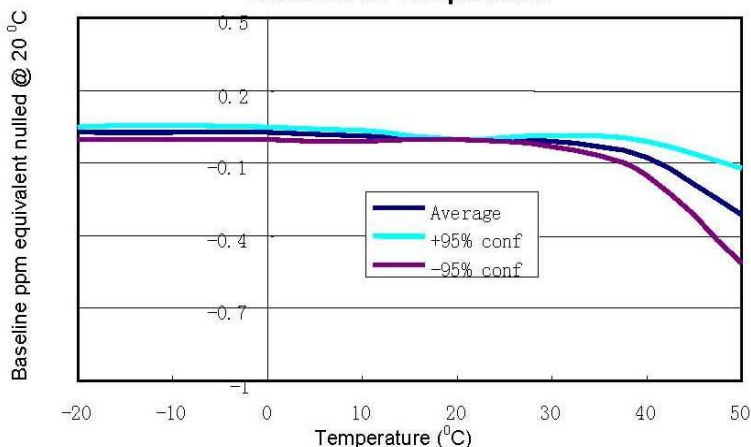

Notes: Sensors are designed to operate in a wide range of harsh environments and conditions. However, it is important to avoid exposure to high concentrations of solvent during storage, fitting into instrumentation and operation. When using sensors on PCBs, degreasing agents should be used prior to the sensor being fitted.

By the nature of the technology used, any sensor can potentially fail to meet specification without warning. Euro-Gas makes every effort to ensure reliability of all sensors but where life safety is a performance requirement of the product and, where practical, Euro-Gas recommends that all gas sensors and instruments using sensors are checked for response to gas before use.

The data contained in this document is believed to be accurate and reliable. The data given is for guidance only. Euro-Gas Management Services Ltd accepts no liability for any consequential losses, injury or damage resulting from the use of this datasheet or the information contained in it. Customers should test the sensors under their own conditions to ensure that the sensors are suitable for their own requirements and in accordance with the plans and circumstances of the specific project and any standards/regulations pertaining to the country in which the sensors will be utilised. Performance characteristics on this data sheet outline the performance of newly supplied sensors. Output signal can drift below the lower limit over time. This datasheet is not intended to form the basis of a contract and in the interest of product improvement, Euro-Gas reserves the right to alter design features and specifications without notice. 01/16

