

GAS MEASURING SYSTEM FOR 4 SERIES AND MICRO SENSORS

1. THE TECHNOLOGY

The Euro-Gas *SenseGas* Measuring System offers a unique advantage - the user can choose from one of a vast range of gas sensors and calibration combinations:

1. **Choose your gas sensor from one of our comprehensive range of 4 series size and micro size industrial and air quality 3-electrode gas sensors.**
2. **Then choose your preferred gas calibration measuring range.**
3. **Select output from:**
 - (a) **CAN bus plus 4-20mA output.**
 - or
 - (b) **CAN bus plus 1-4Vdc output.**



SenseGas Measuring System in aluminium housing
suitable for 4 series size
or micro size sensors
Part no: 2112B24420

The *SenseGas* Measuring System is suitable for gas detection applications in ambient air. The system is temperature compensated for -25°C to $+85^{\circ}\text{C}$ and relative humidity of 5 to 95% RH (non-condensing). Please refer to individual chosen sensor datasheet for operating conditions of corresponding sensor.

Different measuring ranges can be selected at the time of order.

Each sensor offer fast response and long service life. The intelligent electronics process the measured values, output the measuring signal, monitor the functioning of the system and report any faults. The system requires a 10Vdc to 24Vdc power supply.



GAS MEASURING SYSTEM FOR 4 SERIES AND MICRO SENSORS

SPECIFICATION

Gas Sensor

Sensor Type:	Electrochemical or solid state sensor
Construction:	3-electrode 4 series size or micro size
Temperature range:	Refer to individual sensor datasheet
Humidity range:	5 to 95% RH, non-condensing
Measuring ranges:	Sensor type and calibrated measuring range according to customer selection
Lowest detectable limit:	Refer to individual sensor datasheet
T90:	Refer to individual sensor datasheet
Cross-Sensitivity:	Refer to individual sensor datasheet



GAS MEASURING SYSTEM FOR 4 SERIES AND MICRO SENSORS

Electronics

Voltage Supply:	10 - 24Vdc
Minimum Voltage:	10Vdc
Maximum Voltage:	27Vdc
Current consumption:	Typically 65mA
Temperature range:	-20°C to + 80°C
Temperature compensation:	-25°C to + 85°C
Alarm relays 1:	Gas high potential free contact C, NC
Alarm relays 2:	Fault for hardware and software. Potential free contact C, NC.
Status LED:	Double function LED: Normal operating - GREEN High gas - RED
Sensor test:	Life test
Current output:	4-20mA or 1-4Vdc (please specify at time of order)
Voltage at current output:	Minimum 12 Vdc, maximum 32 Vdc
Contact 1:	4 pole for CAN-Bus connection. Only with Chamber.
Contact 2:	8 pole plug for unit connection M12 type Binder. Only with Chamber.
Electrical protection:	Short circuit proof
Potting:	Filled with sealing compound Flame proof E96 certificate. Only with Chamber.
Chamber:	Aluminium. Dimensions: length 85mm x width 45mm x height 32mm
Weight:	Approx. 300grams
Assembly:	TS 35 rail
Part no:	2112B24420



GAS MEASURING SYSTEM FOR 4 SERIES AND MICRO SENSORS

Description of functions

Sensor failure / Sensor Defect

The sensor signals a defect if the recorded sensor tension is longer than an adjustable time (1-255 seconds) or if the sensor is damaged mechanically or fails (specification 5 seconds).

Excess temperature

The signal for excess temperature is set at a value less than -25°C or above $+85^{\circ}\text{C}$.

Data disturbance

The data disturbance signal is set if the conveyance of EEPROM data to the processor shows an error. The relay fault triggers and the contact is potential free.

Gas alarm

The gas alarm signal is activated by the processor, directly on the relay and when the adjusted threshold is exceeded. The contact is potential free.

Life test

The life test is a direct functional test of the sensor. A specific tension signal is sent by the processor and will generate a voltage signal directly to the anode on the sensor. The resulting signal has an amplitude height that conveys information about the quality condition of the sensor. If the intended height of amplitude is not reached, then the hardware fault is activated. In this case, the sensor must be exchanged.



GAS MEASURING SYSTEM FOR 4 SERIES AND MICRO SENSORS

EEprom Processor Status Control

Bits in Sensor status:

Bit 7: Hardware Error/	1 = General hardware fault
Bit 6: Kom Error/	1 = Data fault CAN
Bit 5: Flash Error/	1 = EEprom fault (CRC/Program code)
Bit 4: Sensor Error/	1 = Sensor casualty / Sensor defective
Bit 3: Over Tmp/	1 = Over temperature
Bit 2: Analog Error/	1 = Analogue output fault
Bit 1: Cal. Mode/	0 = Normal operation / 1 = Calibration operation
Bit 0: Com Mode/	1 = Communications mode for permanent operation

The sensor and electronics are developed according to the following guidelines;

- EN 60079-0:2009 general request
- EN 610079-11:2007 intrinsically safe
- EN 60079-18:2004

Notes: Sensors and systems are designed to operate in a wide range of harsh environments and conditions. However, it is important to avoid exposure to high concentrations of solvent during storage and operation.

By the nature of the technology used, any sensor can potentially fail to meet specification without warning. Euro-Gas makes every effort to ensure reliability of all sensors but where life safety is a performance requirement of the product and, where practical, Euro-Gas recommends that all gas sensors and instruments using sensors are checked for response to gas before use.

The data contained in this document is believed to be accurate and reliable. The data given is for guidance only. Euro-Gas Management Services Ltd accepts no liability for any consequential losses, injury or damage resulting from the use of this datasheet or the information contained in it. Customers should test the sensors under their own conditions to ensure that the sensors are suitable for their own requirements and in accordance with the plans and circumstances of the specific project and any standards/regulations pertaining to the country in which the sensors will be utilised. Performance characteristics on this data sheet outline the performance of newly supplied sensors. Output signal can drift below the lower limit over time. This datasheet is not intended to form the basis of a contract and in the interest of product improvement, Euro-Gas reserves the right to alter design features and specifications without notice. 08/17



Main functions of 1-4Vdc Circuitry

Sensorsystem

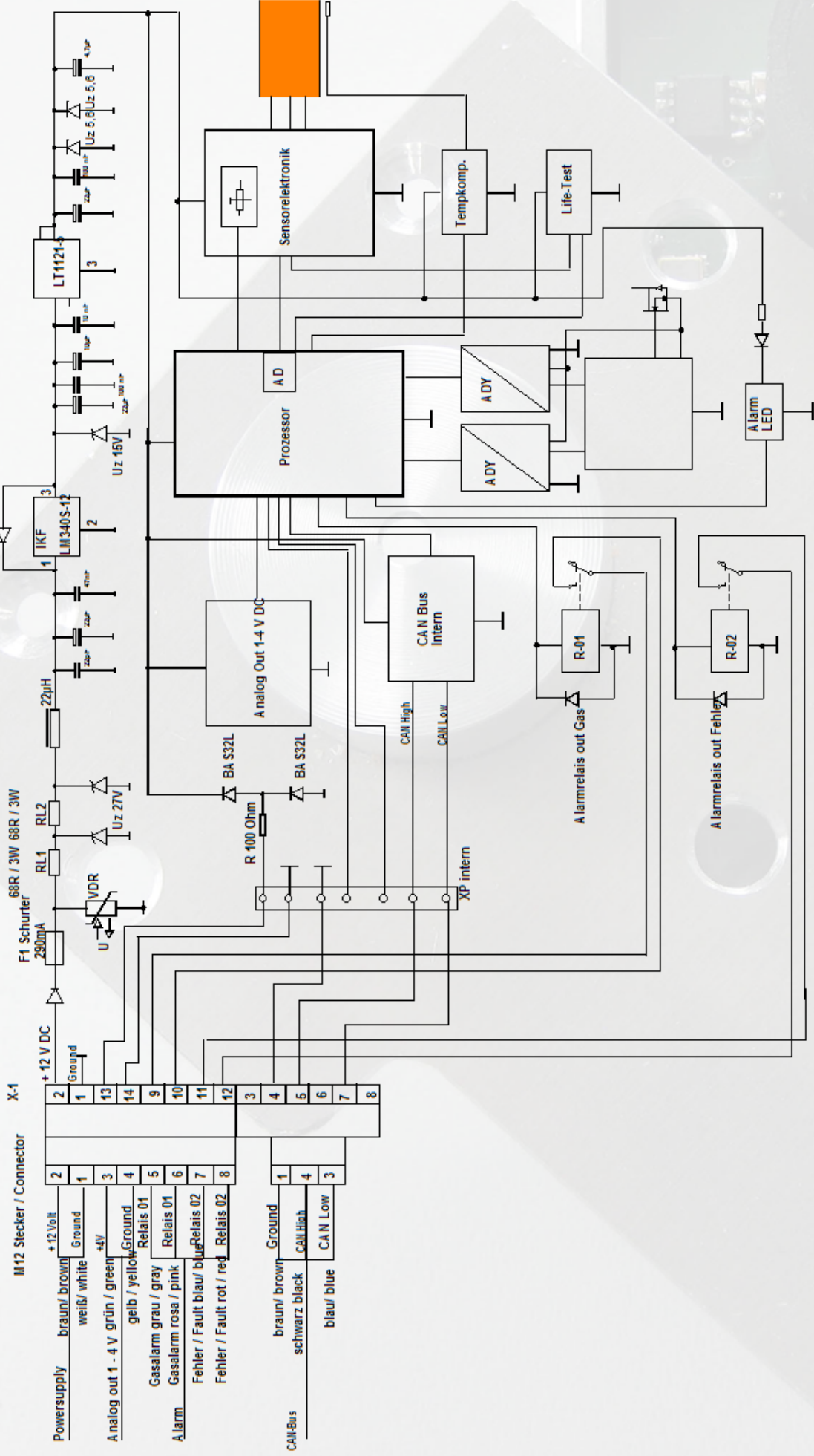

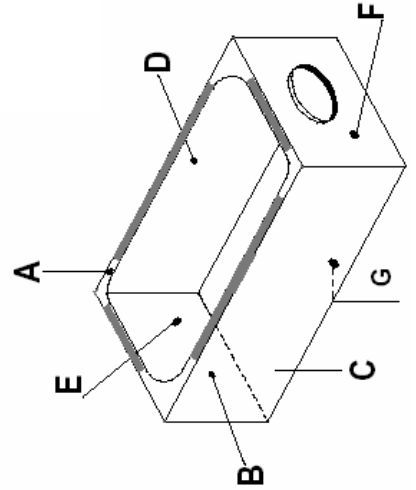
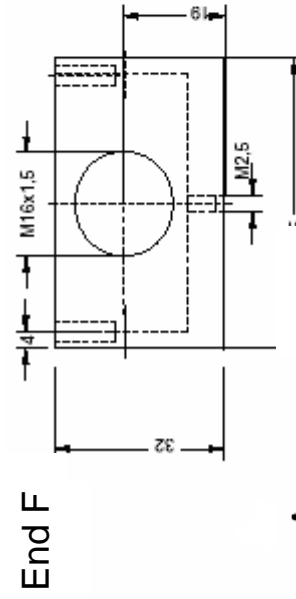
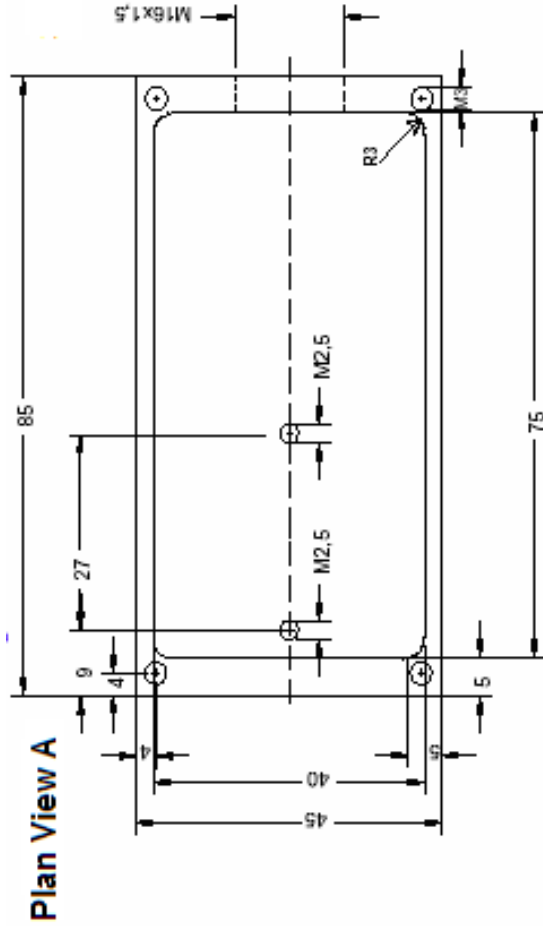
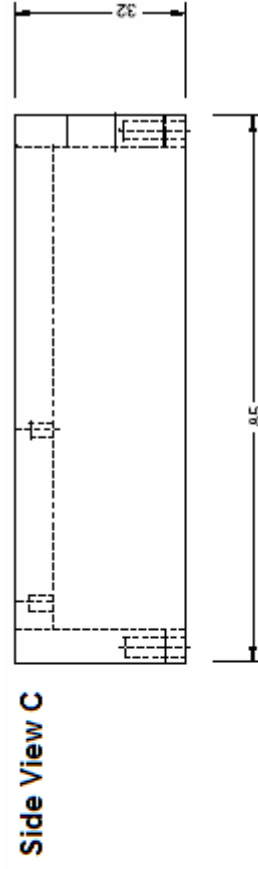
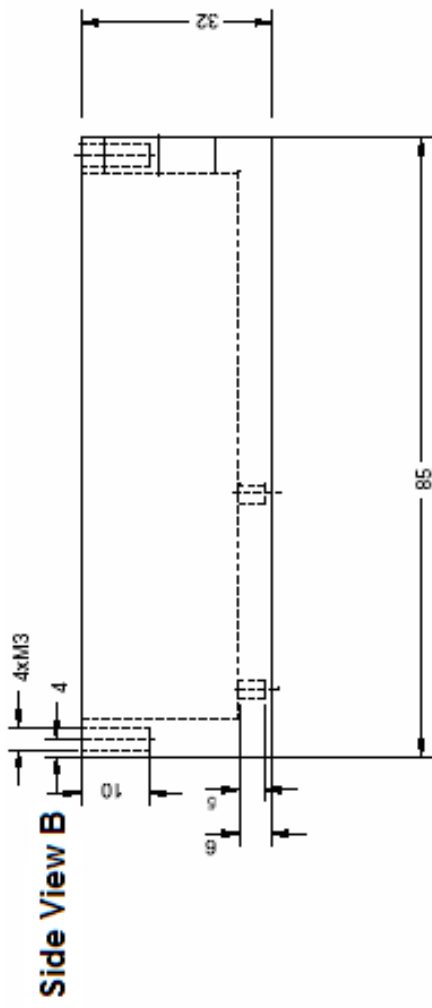

Sensor Housing Dimensions

Side View B

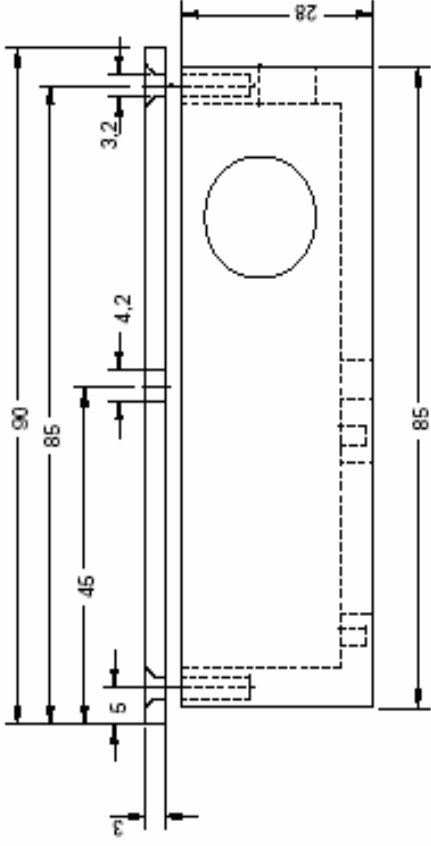

End F

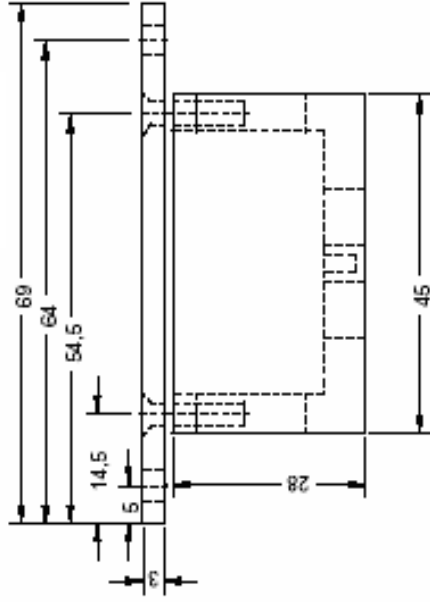

Back Plate

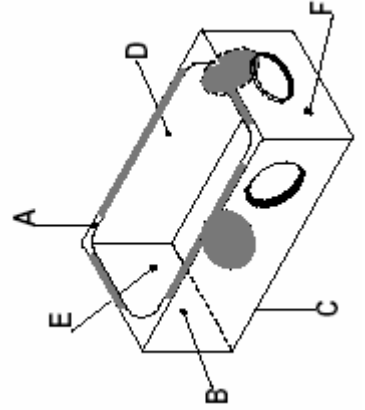
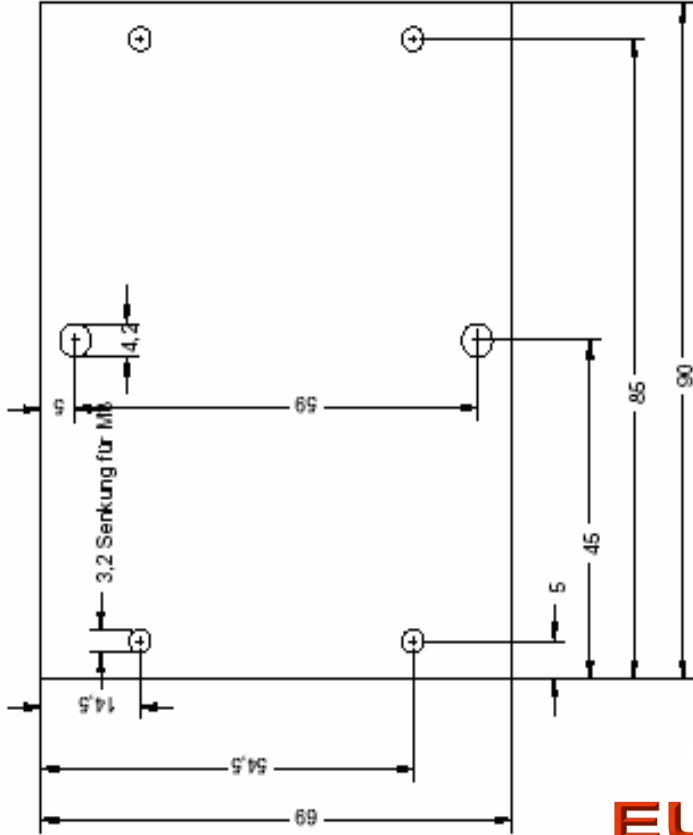

Sensor Housing Dimensions

Optional Accessories

(1) Cabling – 1-4Vdc output option. Part no. 2112B24420CAB

A connection cable is available for the 1-4Vdc output option as an optional accessory. This has an 8pin female plug and M12 thread on one side. The other side of the cable remains open for connection following connection diagrams below:

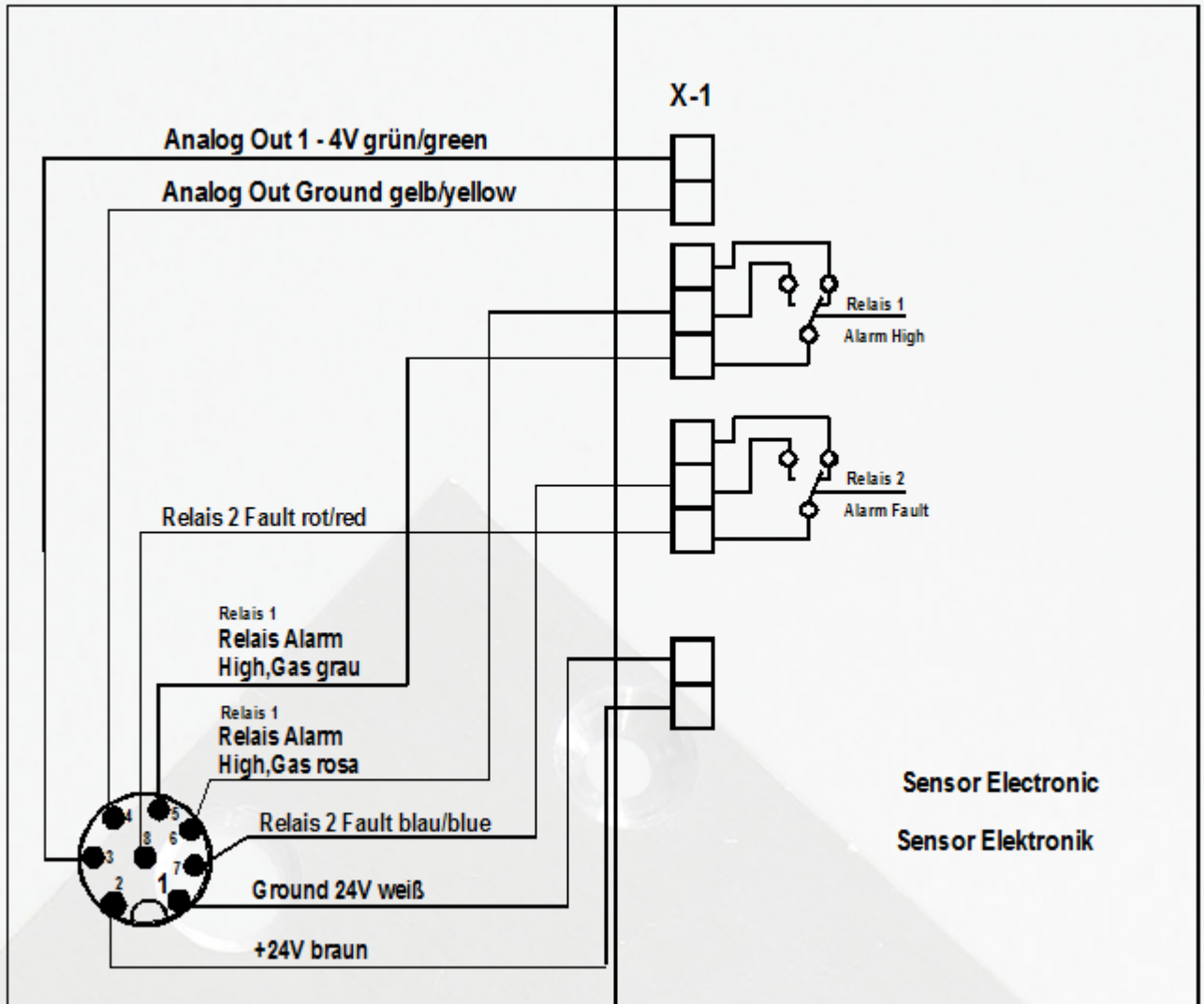







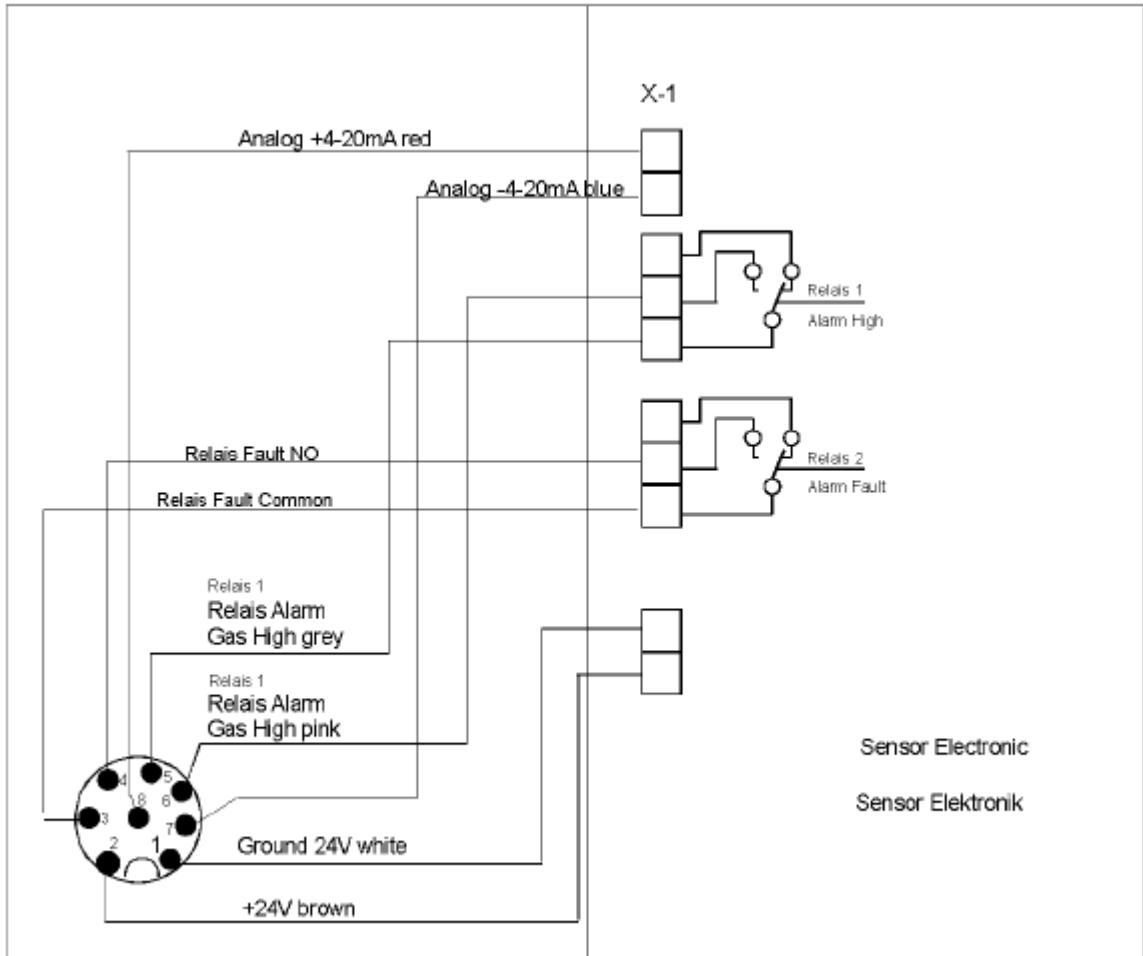

Steckbuchse connecting plug	1	Ground 24V weiß	white	
	2	+24V braun	brown	
	3	Analog 1- 4V + grün	green	
	4	Analog 1- 4V ground gelb	yellow	
	5	Relais Alarm High Common grau	gray	
	6	Relais Alarm High NO rosa	pink	
	7	Relais Fault Alarm NO blau	blue	
	8	Relais Fault Alarm Common rot	red	

Optional Accessories

(2) Cabling – 4-20mA output option. Part no. 2112B24420CAB

A connection cable is available for the 4-20mA output option as an optional accessory. This has an 8pin female plug and M12 thread on one side. The other side of the cable remains open for connection following connection diagrams below:



Steckbuchse connecting plug	1	Ground 24V weiß	white	
	2	+24V braun	brown	
	3	Relais Fault Common	green	
	4	Relais Fault NO	yellow	
	5	Relais Alarm High Common	gray	
	6	Relais Alarm High NO	pink	
	7	Analog -4-20mA	blue	
	8	Analog +4-20mA	red	

Optional Accessories

(3) Special Application Gas Caps. Part no. 2112B24420CAP

The standard version of the detector includes an aluminium gas cap.

Alternative industrial applications may require a stainless steel gas cap, for example in car manufacturing or fuel cell applications. Please advise should you require a different type of cap and we will be please to provide further details:

